

## Overview

---

400-watt, portable PA system with 8-channel powered mixer, two 8" speakers, iPod/iPhone USB connection, SPX digital reverbs, an onboard feedback suppressor and versatile EQ.



## Features

---

- 400W (200W + 200W) power output
- Newly designed high quality speakers (LF:8" woofer/ HF:1" voice coil compression driver)
- Detachable 8-channel mixer (4 mono/line + 4 mono / 2 stereo line)
- iPod/ iPhone USB connection
- 1-Knob Master EQ™ with virtual bass boost
- High resolution SPX digital reverbs (4 types, parameter control)
- Onboard feedback suppressor
- Great-sounding 2-band channel EQ
- Switchable stereo/ mono inputs
- Hi-Z (high impedance) inputs
- Phantom power
- Monitor and Subwoofer outputs
- Optional reverb footswitch

## Specifications

1/2

### General Specifications

#### System

System Type	Powered mixer with 2 passive speakers
Frequency Range (-10dB)	55Hz-20kHz
Maximum SPL (Measured Peak IEC Noise@1m)	125dB SPL / speaker
Power Consumption	30W (Idle), 70W (1/8 Power)
Power Requirements	100V-240V, 50Hz/60Hz
Dimensions (W×H×D)	Speaker: 289mm x 472mm x 275mm (11.4" x 18.6" x 10.8"), Mixer: 308mm x 180mm x 116mm (12.1" x 7.1" x 4.6")
Net Weight	17.8kg / 39.2lbs (2 x Speaker 7.5kg + Mixer 2.8kg)

#### Powered Mixer

Mixer	Mixing Channels	8
	Analog Inputs	4 mono mic/line + 4 mono / 2 stereo line
	Digital Inputs	USB Audio IN: iPod/iPhone exclusive
	Channel EQ	2-band (HIGH Shelving: 8kHz, LOW Shelving: 100Hz)
	Channel Functions	Hi-Z switch: CH4, ST/MONO switch: CH5/6-7/8
	Digital Effects	SPX digital reverb (4 program, parameter control)
	Output Processing	Feedback suppressor, 1-Knob Master EQ™
	Phantom Power	+30V (CH1, 2)
	Outputs	SPEAKERS OUT (L, R), MONITOR OUT (L/MONO, R), SUBWOOFER OUT (MONO) with auto HPF
	Control and Others	Reverb foot switch
Built in Amplifiers	Power Rating (Dynamic)	400W (200W + 200W)
	Power Rating (Continuous)	360W (180W + 180W)

#### Speaker

Type	Two-way bass-reflex speakers
Components	LF: 8" (20cm) cone, HF: 1" (2.54cm) voice coil compression driver
Coverage Angle	90° x 60°
Floor Monitor Angle	50°
Handle	Top x 1
Pole Socket	34.8-35.2mm pole socket with StageLok™

#### Accessories

Included Accessories	Cover panel, Power cord (2m), Speaker cables (6m) x 2, Non-skid pads x 12
Optional Accessories	Yamaha BMS10A (mic stand adaptor) for mixer mount, FC5 (footswitch) for reverb ON/OFF

## Specifications

2/2

### Analog Input Specifications

Input Terminals	MIC/LINE	Input Impedance	Source Impedance	Input level			Connector	
				Sensitivity	Nominal	Max. before Clip		
CH IN 1-2	MIC	3k $\Omega$	150 $\Omega$ Mics	-56 dBu	-35 dBu	-10 dBu	XLR-3-31	
	LINE			-30 dBu	-9 dBu	+16 dBu		
CH IN 3-4	MIC	3k $\Omega$	150 $\Omega$ Mics	-56 dBu	-35 dBu	-10 dBu	XLR	XLR Combo
	LINE			-30 dBu	-9 dBu	+16 dBu		
	MIC	10 k $\Omega$ (Hi-Z 1 M $\Omega$ )	150 $\Omega$ Lines (Hi-Z 10 k $\Omega$ )	-50 dBu	-29 dBu	-4 dBu	Phone	
	LINE			-24 dBu	-3 dBu	+22 dBu		
CH IN 5/6	LINE	10 k $\Omega$	150 $\Omega$ Lines	-24 dBu	-3 dBu	+22 dBu	Phone**, RCA Pin	
CH IN 7/8	LINE	10 k $\Omega$	150 $\Omega$ Lines	-24 dBu	-3 dBu	+22 dBu	Phone**, Stereo Mini	

### Output Specifications

Output Terminals	Output Impedance	Load Impedance	Output Level				Connector
			Nominal	Max. before Clip	Typ at THD+N 10%	Dynamic	
SPEAKERS OUT [L,R]	<0.1 $\Omega$	4 $\Omega$ Speakers	-	-	180 W	200 W	Phone**
MONITOR OUT [L,R]	600 $\Omega$	10 k $\Omega$ Lines	+4 dBu	+20 dBu	-	-	Phone**
SUBWOOFER OUT	150 $\Omega$	10 k $\Omega$ Lines	-3 dBu	+17 dBu	-	-	Phone**

### Digital Input Specifications

Terminal	Format	Connector
USB IN	iPod, iPhone exclusive	USB A type

## Dimensions

Unit: mm (inch)

### Mixer

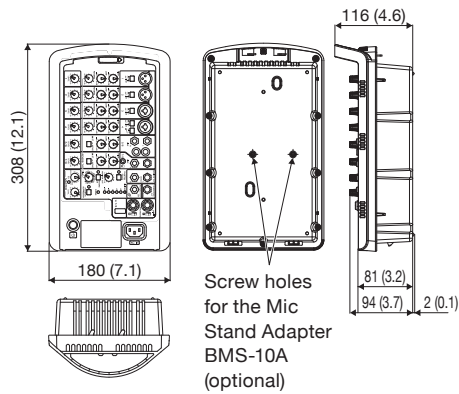

### Speaker

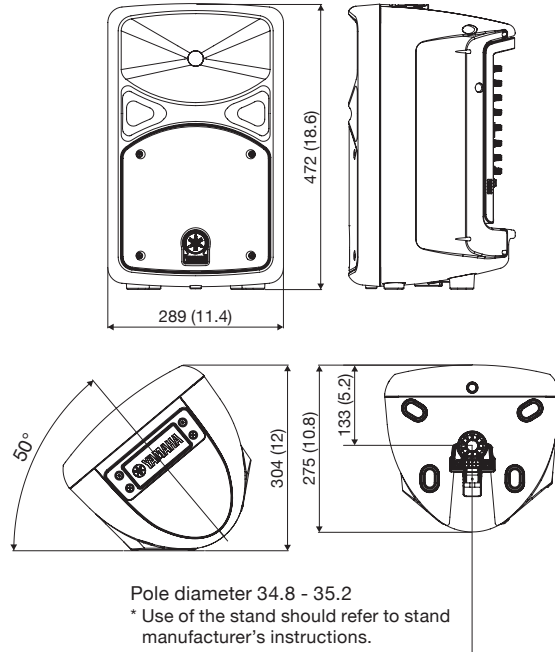

## Options

- Mic Stand Adaptor BMS10A
- Foot Switch FC5

## Architectural and Engineering Specifications

---

The Yamaha STAGEPAS 400i shall be a portable PA system that incorporates a powered mixer with a pair of passive speakers.

The mixer section of the powered mixer shall have 8 analog mixing channels (4 mono microphone/line + 4 mono/2 stereo line) and a digital USB Audio IN input exclusively for iPad/iPhone. The STAGEPAS 400i shall have 2-band channel EQ (HIGH Shelving at 8kHz, LOW Shelving at 100Hz), a Hi-Z switch on channel 4, ST/MONO switches for channels 5/6 and 7/8, SPX digital reverb with 4 programs and parameter control, a feedback suppressor, 1-Knob Master EQ™, and +30V phantom power on channels 1 and 2. Outputs shall be SPEAKERS OUT (L and R), MONITOR OUT (L/MONO and R), and SUBWOOFER OUT (MONO) with auto HPF. A Reverb foot switch connector shall be provided.

The amplifier section of the powered mixer shall have a universal power supply that accepts AC line input from 100V to 240V at 50Hz or 60Hz.

The power output rating shall be 400 watts (200 watts + 200 watts) dynamic, or 360 watts (180 watts + 180 watts) continuous.

The loudspeakers shall incorporate a single 8" cone for the low frequencies and a compression driver with a 1" voice coil for the high frequencies.

The loudspeakers shall meet the following performance criteria: Maximum SPL shall be 125dB at 1 meter, frequency response shall be 55 Hz ~ 20 kHz at 10dB below rated sensitivity, and nominal coverage angle shall be 90° horizontal and 60° vertical. The loudspeaker shall have a 50° floor monitor angle, a top handle, and a 34.8 ~ 35.2 mm pole socket with StageLok™.

Powered mixer dimensions shall be 308 (W) x 180 (H) x 116 (D) mm. Powered mixer weight shall be no more than 2.8 kg. The dimensions of each loudspeaker shall be 289 (W) x 472 (H) x 275(D) mm. The weight of each loudspeaker shall be no more than 7.5 kg. Total PA system weight shall be 17.8 kg.

Accessories included with the portable PA system shall be: cover panel, power cord (2 meters), 2 speaker cables (6 meters each), 12 non-skid pads.

# Block Diagrams

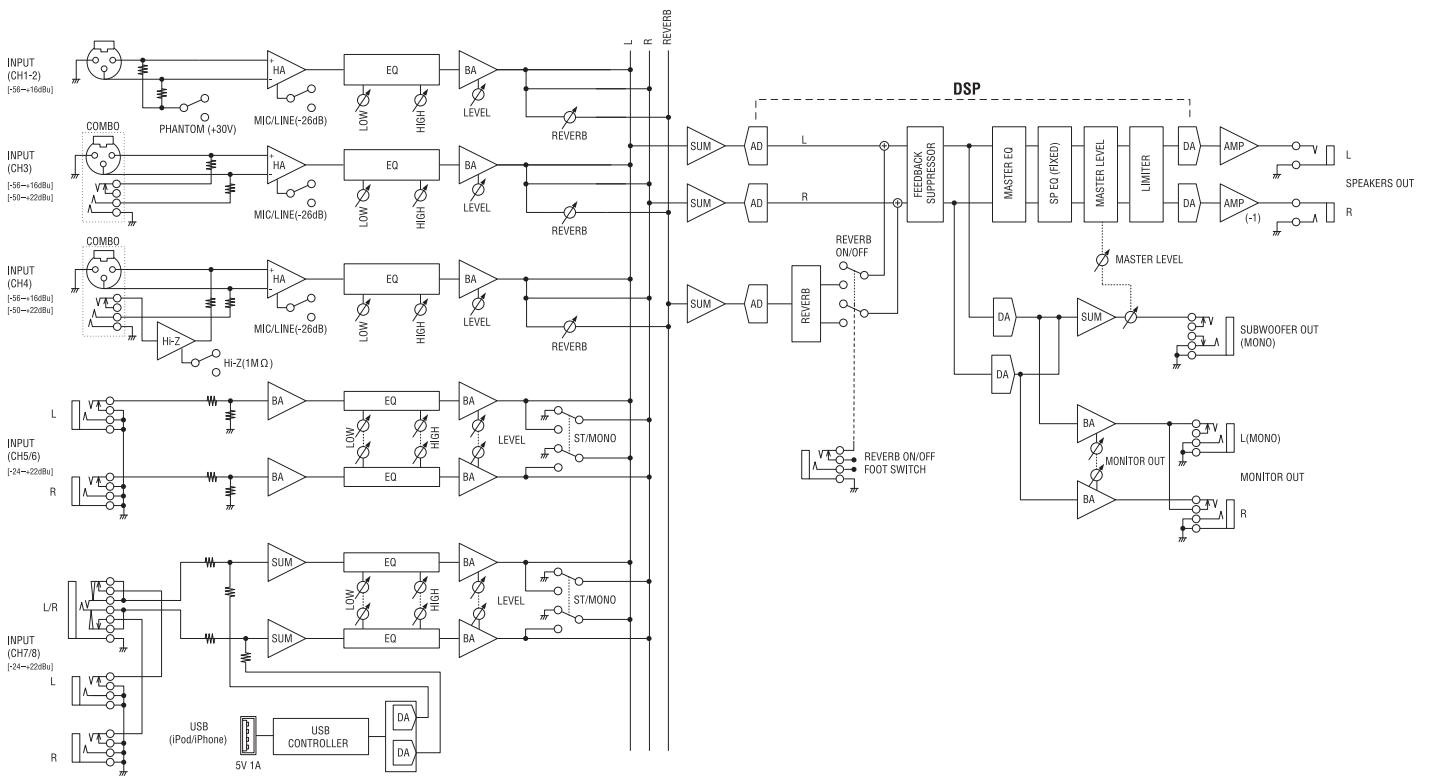

\*All information subject to change without notice.  
 \*All trademarks and registered trademarks are property of their respective owners.  
 Created in March, 2017



YAMAHA CORPORATION  
 P.O.BOX 1, Hamamatsu Japan  
[www.yamahaproaudio.com](http://www.yamahaproaudio.com)