

Part Number according to Shell Finish and Colour Insulator

CAT P/No.	REF P/No.	SHELL FINISH	INSULATOR COLOUR
ACJD-BLK	55010329-000	NICKEL	BLACK
ACJD-RED	55010329-001	NICKEL	RED
ACJD-ORG	55010329-002	NICKEL	ORANGE
ACJD-YEL	55010329-003	NICKEL	YELLOW
ACJD-GRN	55010329-004	NICKEL	GREEN
ACJD-BLU	55010329-005	NICKEL	BLUE
ACJD-VIO	55010329-006	NICKEL	VIOLET
ACJD-GRY	55010329-007	NICKEL	GREY
ACJD-WHT	55010329-008	NICKEL	WHITE
ACJB-BLK	55010329-009	MATT BLACK	BLACK
ACJB-RED	55010329-010	MATT BLACK	RED
ACJB-ORG	55010329-011	MATT BLACK	ORANGE
ACJB-YEL	55010329-012	MATT BLACK	YELLOW
ACJB-GRN	55010329-013	MATT BLACK	GREEN
ACJB-BLU	55010329-014	MATT BLACK	BLUE
ACJB-VIO	55010329-015	MATT BLACK	VIOLET
ACJB-GRY	55010329-016	MATT BLACK	GREY
ACJB-WHT	55010329-017	MATT BLACK	WHITE

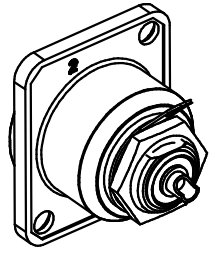
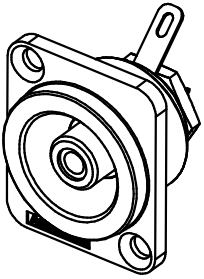
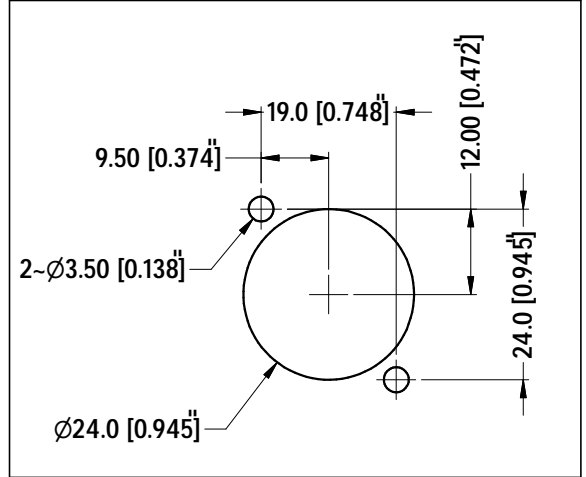
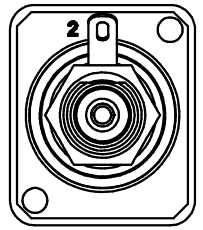
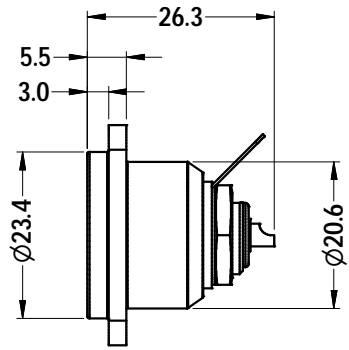
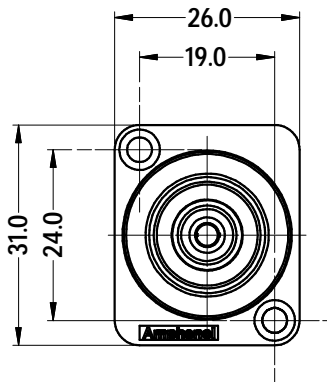

ISO VIEW

UNLESS OTHERWISE SPECIFIED TOLERANCE TO BE		THIS DOCUMENT IS THE PROPERTY OF AMPHENOL AUSTRALIA PTY. LTD.. NO PART THEREOF MAY BE REPRODUCED AND USED WITHOUT THE PRIOR WRITTEN CONSENT OF THE OWNER				1	UPDATE TO MODIFIED COMPONENTS ADD SHEET 2 OF 2 FOR CUSTOMER DRAWING	LV	23-11-05	8462
LINEAR		ANGULAR		CAD FILE: 55010329000221	DRN: L.V	DATE: 02-07-05	0			
X ± 0.5	X' ± 1			MATL: REFER TO COMPONENT	CKD: M.N.H	DATE: 04-05-06	FIRST ISSUE			
XX ± 0.1	XX' ± 30'			FINISH: REFER TO COMPONENT	APP'D: P.M	DATE: 04-05-06	L.V			
XXX ± 0.05	XXX' ± 15'			DO NOT SCALE		REV.		BY	DATE	CHG/No
BREAK ALL SHARP EDGES AND REMOVE ALL BURRS				DIMENSIONS IN MILLIMETRES		SCALE: 1:1 UOS		PART No: REFER TO TABLE		SIZE: A4
DO NOT SCALE				THIRD ANGLE PROJECTION		TITLE: RCA & D-SHELL CONNECTOR CUSTOMER DWG		DRAWING NO. 55010329-000-2		SHEET 2 OF 2

Amphenol
Amphenol Australia Pty Ltd, 2 Fiveways Blvd, Keilorborough, Vic.3172
DRAWING NO. 55010329-000-2 SHEET 2 OF 2