

# ***HD Color Video Camera***

---

## **Technical Manual**



## **SRG-300H**

# Table of Contents

- Features..... 3**
- Connection..... 4**
- System Configuration ..... 5**
- Locations of Controls ..... 7**
- Basic Functions ..... 10**
  - Overview of Functions..... 10
  - Initial Settings and Preset..... 17
  - Mode Condition ..... 18
- Command List..... 23**
  - VISCA RS-232/RS-422 Commands ..... 23
  - IP Related Setting Command ..... 33
  - SRG-300H Commands ..... 35
- Specifications ..... 53**
- Precautions ..... 59**

# Features

- The 1/2.8 type Exmor CMOS camera (utilising approximately 2 million valid pixels) allows for high-definition shooting with superior picture quality.
- Adopts 30 times optical magnification, F1.6 high power and luminous zoom lens.
- By adopting its wide and dynamic range functions, you can see the optimised shooting image which incorporates bright and dark subjects at the same time.
- Adopts the industry standard RS-232 interface of VISCA camera protocol in external communication. It is possible to operate from long distances by using both RS-232 and RS-422.
- You can install the camera on ceilings due to the functions of high-speed and wide range pan/tilt action and vertical image flip.
- You can use the infrared remote commander to set the camera and also to select panning, tilting and zooming from the setting menu.
- You can store up to 16 kinds of camera direction and camera status into the camera. In the case of the infrared remote commander, 6 kinds can be stored.
- You can use the LAN cable for external communication. This will make system construction easier.
- The camera can be set for a variety of HD video formats and has an HDMI interface terminal. The HDMI video interface is in widespread use.

# Connection

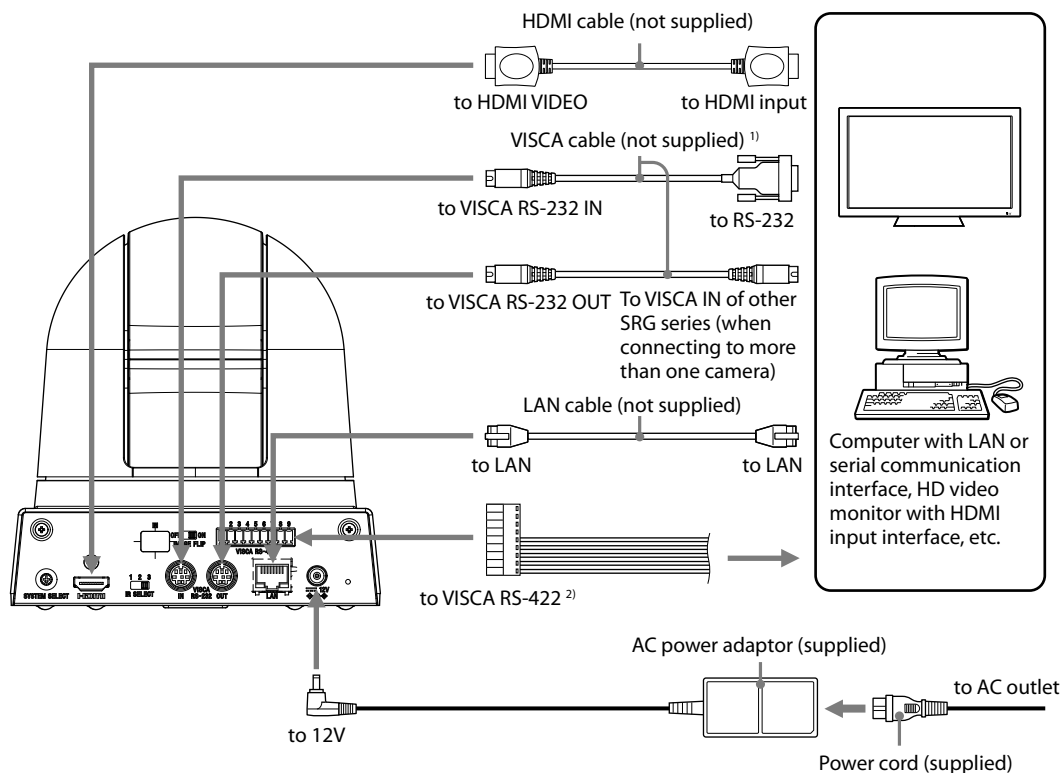

- 1) When the camera is connected to a computer with a VISCA cable (cross type, RS-232), you can operate the camera with the computer. To obtain a cable, consult the dealer where you bought your camera.
- 2) For details on how to connect using VISCA RS-422, see page 57.
- 3) For details on the VISCA over IP connection using LAN cable, see page 29.

## Notes

- Use only the AC power adaptor (JEITA type4) supplied with the unit. Do not use any other AC power adaptor.



Polarity of the plug

- You have to set the video format of the signal to be output from the camera. For detailed information on how to set the video format, see “**8** SYSTEM SELECT switch” on page 8.
- Do not make VISCA RS-232 and RS-422 connections at the same time, as this may cause malfunctions.

# System Configuration

The SRG-300H has various system configuration capabilities using optional products. This section describes three typical system examples with the required components and the main usage of each system.

## Operating a SRG-300H Using the Supplied Infrared Remote Commander

### This system allows you:

To operate the camera readily from a short distance

### System configuration

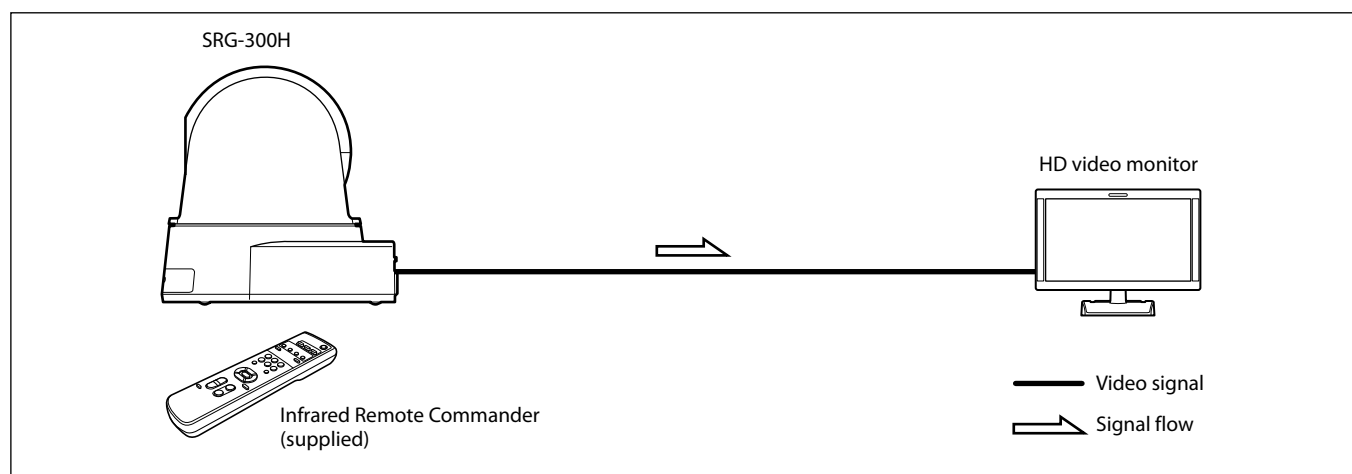

## Operating a SRG-300H Using the RM-IP10 IP Remote Controller

### This system allows you:

To perform pan/tilt and zoom operations using the joystick of the IP remote controller, and to perform the Preset operation using the button.

### System configuration

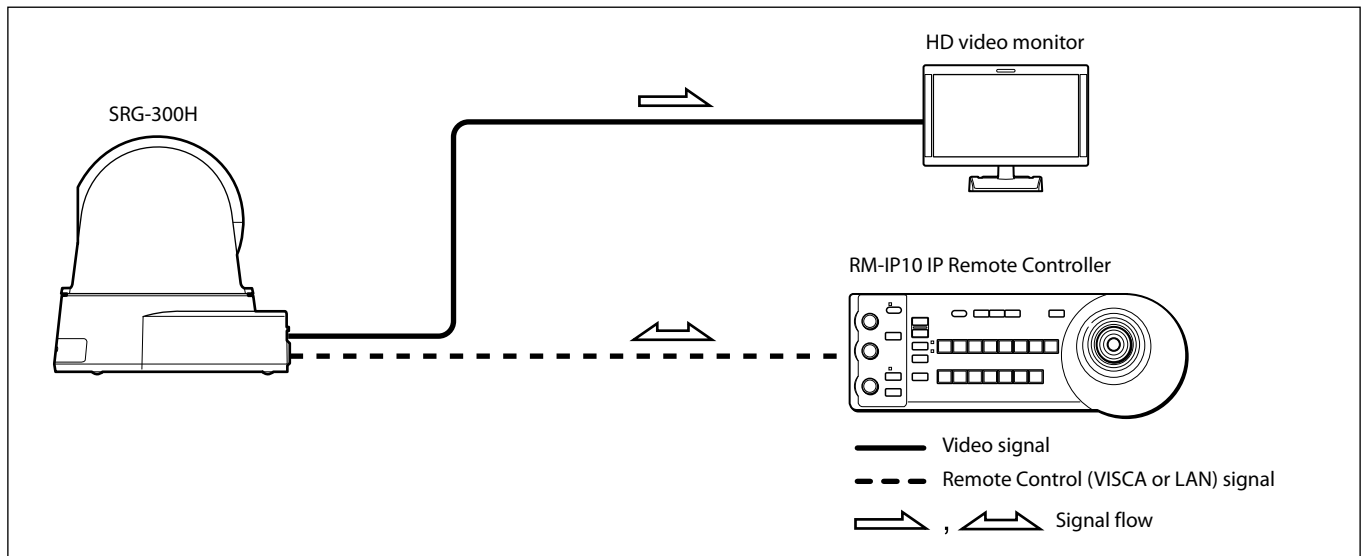

## When Operating Multiple SRG-300H Cameras Using Multiple RM-IP10 IP Remote Controllers

### System configuration

- You can operate up to 112 cameras using five IP remote controllers.
- The joystick of the IP remote controller allows comfortable pan/tilt and zoom operations.

### System configuration

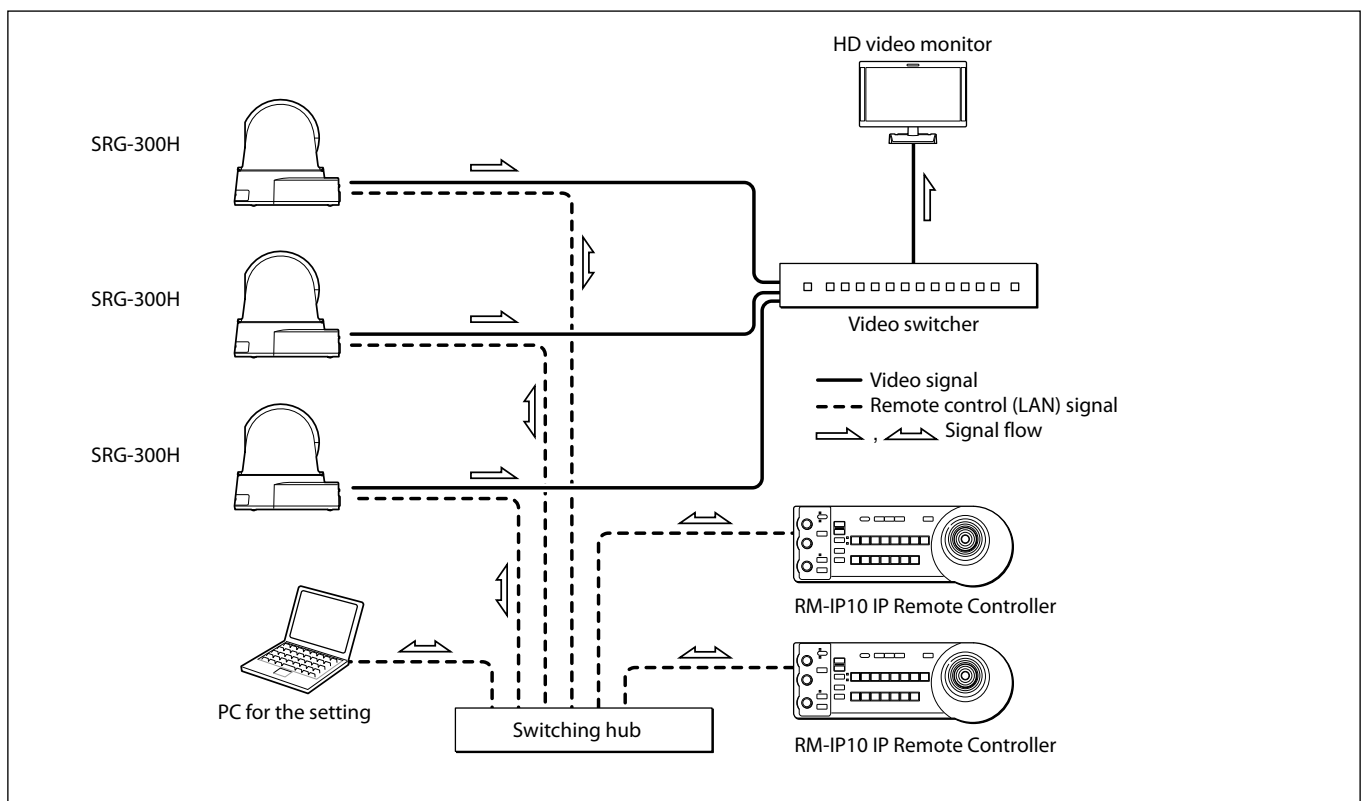

### Note

You cannot use the RS-232 and RS-422 connections when using the LAN connection.

# Locations of Controls

## Camera

### Front

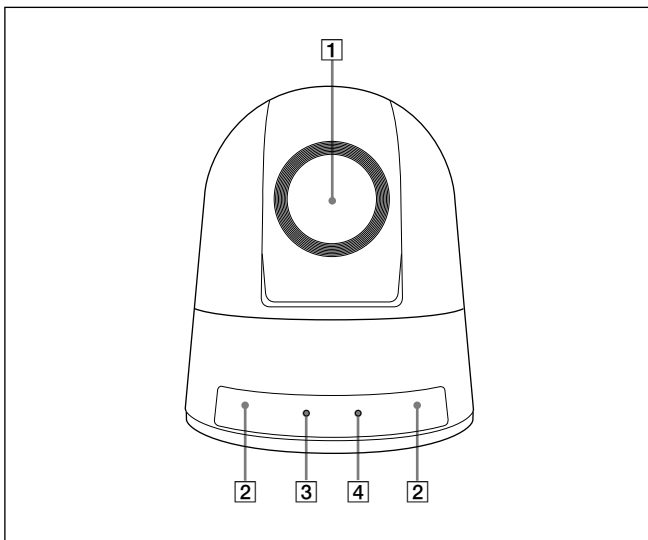

- 1 Lens**  
This is a 30-magnification optical zoom lens.
- 2 Infrared remote commander sensors**  
These are sensors for the supplied infrared remote commander.
- 3 POWER lamp**  
Lights in green when the camera is connected to an AC outlet using the supplied AC power adaptor and AC power cord.  
Flashes in green when the camera receives an operation command from the supplied infrared remote commander.  
When the power is turned on, it takes about 15 to 30 seconds to display the image after the lamp lights.
- 4 STANDBY lamp**  
Lights in amber when the power is turned off using the infrared remote commander.

### Rear

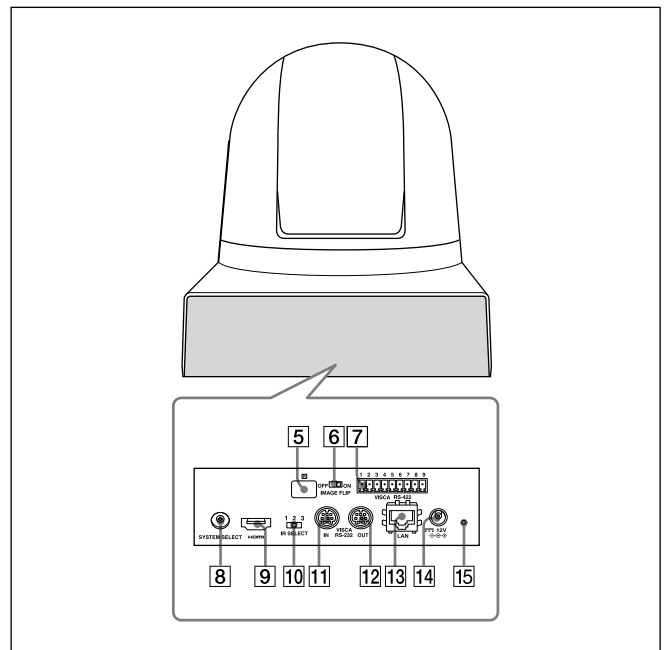

- 5 Infrared remote commander sensors**  
These are sensors for the supplied infrared remote commander.
- 6 IMAGE FLIP switch**  
Flips the image upside down. Normally set this to OFF when you use the camera. When the camera is attached to the ceiling, set this to ON. Turn off the unit before setting the IMAGE FLIP switch. Then, turn the power on by connecting the power adaptor, by VISCA CONTROL or the infrared remote commander. When you switch IMAGE FLIP, the preset setting is returned to the initial setting.
- 7 VISCA RS-422 connector**  
To communicate via RS-422, use this connector. Use the supplied VISCA RS-422 connector plug.

**8 SYSTEM SELECT switch**

Used for setting the video format of the signal to be output from the HDMI VIDEO connectors.

For details, see "Setting of the SYSTEM SELECT switch" (page 8).

**9 HDMI video connector**

Supplies the images as a HDMI video signal or DVI video signal.

**10 IR SELECT switch**

Select the camera number when you operate multiple cameras with the same infrared remote commander.

**11 VISCA IN connector**

Connect to a computer via an RS-232 interface. When you connect multiple cameras, connect it to the VISCA OUT connector of the previous camera in the daisy chain connection.

**12 VISCA OUT connector**

When you connect multiple cameras, connect it to the VISCA IN connector of the next camera in the daisy chain connection.

**13 LAN connector (RJ-45 8-pin)**

Connect to a switching HUB that is compatible with 10BASE-T/100BASE-TX using a LAN cable (category 5 or higher, shielded twisted pair).

When a link is established, the green indicator lights, and it flashes during communication. While connected with 100BASE-TX, the yellow indicator also lights.

**Note**

For safety, when connecting the peripheral device, do not connect the connector that might have excessive voltage to this connector. Follow the Operating Instructions for the connection.

**14 12 V connector**

Connect the supplied AC power adaptor.

**15 Reset switch**

The reset switch is enabled only when the BOTTOM switch is set to the LAN connection. When you press down this switch with a pointed tip for about five seconds, the camera will reboot and only the setting relating to the IP will return to the factory setting.

**Factory settings for IP**

IP address: 192.168.0.100

Subnet mask: 255.255.255.0

Name: CAM1

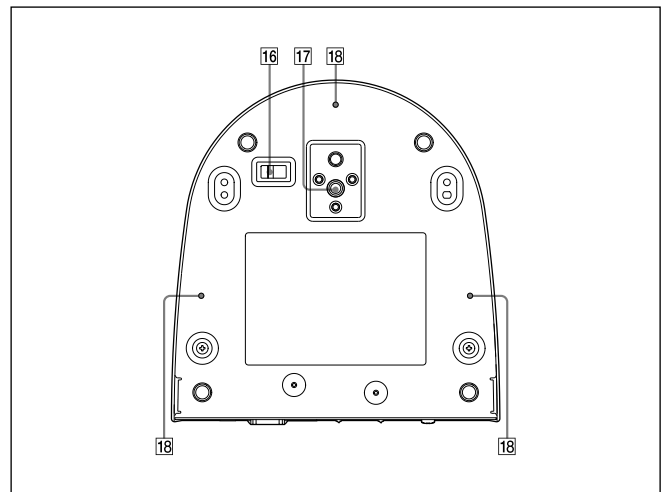
**Bottom****16 BOTTOM switches**

Used for LAN and VISCA CONTROL switching, RS-232 and RS-422 switching, 9,600 bps and 38,400 bps baud rate selection and IR signal output setting.

For details, refer to the setting of the BOTTOM switches (page 9).

**17 Tripod screw hole****18 Fix-mounting screw holes****Setting of the SYSTEM SELECT switch**

This switch allows you to select the video format of the signal to be output from the HDMI video connector.

SRG-300H

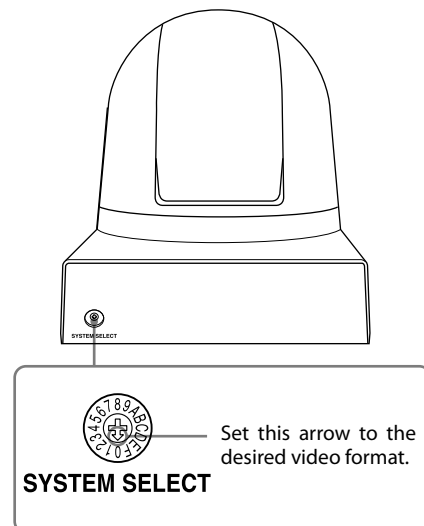



Switch position	Video format	
0	1920×1080p/59.94	59.94 Hz system
1	No output	
2	1920×1080p/29.97	
3	1920×1080i/59.94	
4	1280×720p/59.94	
5	1280×720p/29.97	
6	EDID	—
7	VISCA CONTROL	—
8	1920×1080p/50	50 Hz system
9	No output	
A	1920×1080p/25	
B	1920×1080i/50	
C	1280×720p/50	
D	1280×720p/25	
E	No output	
F	No output	—

### Notes

- Be sure to set this switch before you turn on the power of the camera. You can also set this switch in the standby mode of the camera. After completing the setting, turn on the power of the camera by connecting it to an AC outlet using the supplied AC power adaptor and AC power cord, by using the VISCA command or infrared remote commander.
- Be sure to use a Phillips-head screwdriver when changing the switch position. If you use a tool other than the designated screwdriver, the crossed groove may be damaged.
- If the switch position is set to 1, 9, E and F (no output), the POWER lamp and STANDBY lamp will both remain lit. In such cases, control via the infrared remote commander and VISCA communication is disabled.
- If the switch position is set to 6 (EDID), the most suitable format will be output automatically based on the resolution of the Video monitor to be connected.
- If the switch position is set to 7 (VISCA CONTROL), you can configure the video format via external communication.

### Setting of the BOTTOM switches

To change the BOTTOM switch setting, select the BOTTOM switch with the power of this unit turned off (not including standby state), and then turn on the DC power. The setting cannot be changed after the power is turned on.

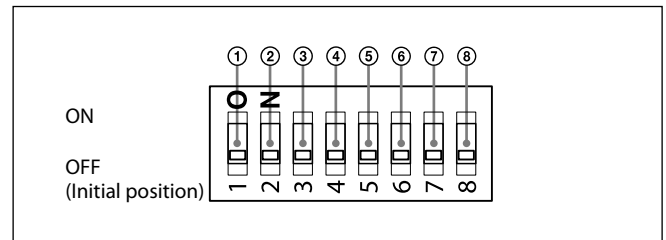

#### ① VISCA/LAN switch

Select the communication method setting.

Set to ON to use the LAN connection and set to OFF to use the VISCA CONTROL (serial control).

#### ② RS-232/RS-422 select switch (when using the serial connection)

Set to OFF to operate the color video camera using the VISCA command via the RS-232 interface. Set to ON to operate it via the RS-422 interface.

#### ③ Baud rate select switch (when using the serial connection)

Set the communication speed in the VISCA CONTROL.

ON: 38,400 bps

OFF: 9,600 bps

#### ④ IR OUT switch

Set to ON to enable output of the receiver signals, which are transmitted from the infrared remote commander via the VISCA IN connector (page 57), or set it to OFF to disable the output.

#### ⑤ Switch 5 (Not used)

Be sure to set this switch to OFF.

#### ⑥ Switch 6 (Not used)

Be sure to set this switch to OFF.

#### ⑦ Switch 7 (Not used)

Be sure to set this switch to OFF.

#### ⑧ Switch 8 (Not used)

Be sure to set this switch to OFF.

# Basic Functions

---

## Overview of Functions

---

### Zoom

The SRG camera employs a 30× optical zoom lens combined with a digital zoom function; this camera allows you to zoom up to 360×.

- **Optical 30×, f = 4.3 mm to 129 mm (F 1.6 to F 4.7)**

Digital Zoom enlarges the center of the subject by expanding each image in both the vertical and horizontal directions. When the digital zoom is used, the resolution deteriorates.

You can activate the zoom in the following modes, all of which can be set using VISCA command.

#### **Standard Mode**

#### **Variable Mode**

There are eight levels of zoom speed.

*In these standard and variable modes, it is necessary to send Stop Command to stop the zoom operation.*

#### **Direct Mode**

Setting the zoom position enables quick movement to the designated position.

#### **Digital Zoom ON/OFF**

#### **Note**

The digital zoom is enabled only when the Video Latency is set to NORMAL.

---

### Focus

Focus has the following modes, all of which can be set using VISCA Commands.

- **Auto Focus Mode**

The Auto Focus (AF) function automatically adjusts the focus position to maximise the high frequency content of the picture in a center measurement area, taking into consideration the high luminance and strong contrast components.

The minimum focus distance is 10 mm at the optical wide end and 1200 mm at the optical tele end.

- **Normal AF Mode**

This is the normal mode for AF operations.

- **Interval AF Mode**

The mode used for AF movements carried out at particular intervals. The time intervals for AF movements and for the timing of the stops can be set in one-second increments using the Set Time Command. The initial value for both is set to five seconds.

- **Zoom Trigger Mode**

When the zoom is changed, the AF mode activates for the pre-set time. Then, it stops. The initial value is set to 5 seconds.

AF sensitivity can be set to either Normal or Low.

- **Normal**

Reaches the highest focus speed quickly. Use this when shooting a subject that moves frequently. Usually, this is the most appropriate mode.

- **Low**

Improves the stability of the focus. When the lighting level is low, the AF function does not take effect, even though the brightness varies, contributing to a stable image.

- **Manual Focus Mode**

Manual Focus has both a Standard Mode and a Variable Mode. Standard Mode focuses at a fixed rate of speed. Variable Mode has eight speed levels that can be set using a VISCA Command.

*In these standard and variable modes, it is necessary to send Stop Command to stop the zoom operation.*

- **One Push Trigger Mode**

When a Trigger Command is sent, the lens moves to adjust the focus for the subject. The focus lens then holds that position until the next Trigger Command is input.

- **Infinity Mode**

The lens is forcibly moved to a position suitable for an unlimited distance.

- **Near Limit Mode**

Can be set in a range from 1000 ( $\infty$ ) to F000 (1 cm). Default setting: D000h (30 cm)

---

## White Balance

White Balance has the following modes.

- **Auto White Balance**

This mode computes the white balance value output using color information from the entire screen. It outputs the proper value using the color temperature radiating from a black subject based on a range of values from 2500K to 7500K.

This mode is the factory setting.

- **ATW**

Auto Tracing White balance (2000K to 10000K)

- **Indoor**

3200K Base Mode

- **Outdoor**

5800K Base Mode

- **One Push WB**

One Push White Balance is a function that forcibly captures the white color once the lighting conditions to illuminate the subject are set, enabling you to shoot the image in the conditions as they are set. By using this function, the natural color of the subject can be obtained without being affected by the surrounding lighting conditions. To set this mode, shoot the subject that you want to capture the white color and send the One Push White Balance Trigger.

The One Push White Balance data is lost when the power is turned off. If the power is turned off, set One Push White Balance again.

- **Manual WB**

Manual control of R and B gain, 256 steps each

## Automatic Exposure Mode

A variety of AE functions are available for optimal output of subjects in lighting conditions that range from low to high.

- **Full Auto**

Iris, Gain and Shutter Speed can be set automatically.

- **Gain Limit Setting**

The gain limit can be set at the Full Auto, Shutter Priority, Iris Priority, Bright and Manual in the AE mode. Use this setting when image signal-to-noise ratio is particularly important.

- **Shutter Priority<sup>1)</sup>**

Variable Shutter Speed, Auto Iris and Gain (1/1 to 1/10,000 sec., 16 high-speed shutter speeds plus 6 low-speed shutter speeds)

1) Flicker can be eliminated by setting shutter to

→ 1/100s for NTSC models used in countries with a 50 Hz power supply frequency

→ 1/120s for PAL models used in countries with a 60 Hz power supply frequency

- **Iris Priority**

Variable Iris (F1.6 to Close, 14 steps), Auto Gain and Shutter speed

- **Manual**

Variable Shutter, Iris and Gain

- **Bright**

Variable Iris and Gain (Close to F1.6, 14 steps and F1.6 at 15 steps)

### AE – Shutter priority

The shutter speed can be set freely by the user to a total of 22 steps – 16 high speeds and 6 low speeds. When the slow shutter is set, the speed can be adjusted the slow shutter according to subject brightness. The picture output is read at a low rate from the memory. AF capability is low.

In high speed mode, the shutter speed can be set up to 1/10,000s. The iris and gain are set automatically, according to the brightness of the subject.

Parameter	59.94/29.97 mode	50/25 mode
15	1/10000	1/10000
14	1/6000	1/6000
13	1/4000	1/3500
12	1/3000	1/2500
11	1/2000	1/1750
10	1/1500	1/1250
0F	1/1000	1/1000
0E	1/725	1/600
0D	1/500	1/425
0C	1/350	1/300
0B	1/250	1/215
0A	1/180	1/150
09	1/125	1/120
08	1/100	1/100
07	1/90	1/75
06	1/60	1/50
05	1/30	1/25
04	1/15	1/12
03	1/8	1/6
02	1/4	1/3
01	1/2	1/2
00	1/1	1/1

### AE – Iris priority

The iris can be set freely by the user to 14 steps between F1.6 and Close.

The gain and shutter speed are set automatically, according to the brightness of the subject.

Parameter	Setting value	Parameter	Setting value
11	F1.6	0A	F5.6
10	F2	09	F6.8
0F	F2.4	08	F8
0E	F2.8	07	F9.6
0D	F3.4	06	F11
0C	F4	05	F14
0B	F4.8	00	CLOSE

### AE – Manual

The shutter speed (22 steps), iris (14 steps) and gain (15 steps) can be set freely by the user.

### AE – Bright

The bright control function adjusts both gain and iris using an internal algorithm, according to a brightness level freely set by the user. Exposure is controlled by gain when dark, and by iris when bright.

As both gain and iris are fixed, this mode is used when exposing at a fixed camera sensitivity. When switching from Full Auto or Shutter Priority Mode to Bright Mode, the current status will be retained for a short period of time.

Only when the AE mode is set to “Full Auto” or “Shutter Priority,” you can switch it to “Bright.”

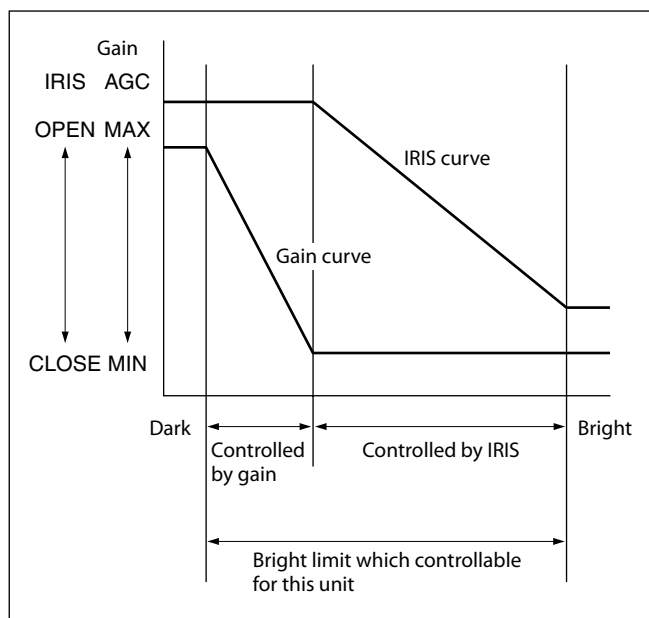

Parameter	Iris	Gain	Parameter	Iris	Gain
1F	F1.6	+43 dB	11	F1.6	0 dB
1E	F1.6	+39 dB	10	F2	0 dB
1D	F1.6	+36 dB	0F	F2.4	0 dB
1C	F1.6	+33 dB	0E	F2.8	0 dB
1B	F1.6	+30 dB	0D	F3.4	0 dB
1A	F1.6	+27 dB	0C	F4	0 dB
19	F1.6	+24 dB	0B	F4.8	0 dB
18	F1.6	+21 dB	0A	F5.6	0 dB
17	F1.6	+18 dB	09	F6.8	0 dB
16	F1.6	+15 dB	08	F8	0 dB
15	F1.6	+12 dB	07	F9.6	0 dB
14	F1.6	+9 dB	06	F11	0 dB
13	F1.6	+6 dB	05	F14	0 dB
12	F1.6	+3 dB	00	CLOSE	0 dB

When switching from the Shutter Priority mode to the Bright mode, the shutter speed set in the Shutter Priority mode is maintained.

### Defog mode

When the surrounding area of the subject is foggy and low contrast, the defog mode will make the subject appear clearer.

---

## Wide Dynamic Range Mode (WD)

The Wide Dynamic Range mode is a function for dividing an image into several blocks and correcting blocked-up shadows and blown-out highlights in accordance with the intensity difference. It enables you to obtain images in which portions ranging from dark to light can be recognized, even when capturing a subject with a large intensity difference that is backlit or includes extremely light portions.

Images with wide dynamic range are produced by combining long-exposure signals (normal shutter) with the signals of the high-intensity portions obtained with a short exposure (high-speed shutter).

### • About WD Set Parameter

(Command: 8x 01 7E 04 00 0p FF)

p: WIDE D (Wide dynamic range mode)

When MODE (exposure mode) is set to FULL AUTO, the camera distinguishes light and dark areas in the same scene, adjusts the brightness for dark areas, and also controls the blown out highlights.

You can select the wide dynamic range mode from among OFF, LOW, MID and HIGH. (0: OFF, 1: LOW, 2: MID, 3: HIGH.)

### Notes

- You can set the wide dynamic range mode when the WIDE D is set to FULL AUTO only.
- When the WIDE D is not set to OFF, the MODE setting is fixed at FULL AUTO.
- When changing the WIDE D, the luminance change of the screen occurs for a moment.
- When the change of exposure is big, the screen may stop for a moment.
- When the wide dynamic range mode is ON, false colors may appear in some parts of the image. This phenomenon is unique to wide dynamic range mode, and is not an indication of a camera malfunction.
- When switching wide dynamic range mode, images are shown at a maximum of 8 frames at the same time.
- When the intensity difference of the image is small, there is no difference in effect between MID and HIGH.

---

## Exposure Compensation

Exposure compensation is a function which offsets the internal reference brightness level used in the AE mode, by steps of 1.5 dB.

The reference brightness is 0.

Parameter	Step	Setting value
0E	+7	+10.5 dB
0D	+6	+9 dB
0C	+5	+7.5 dB
0B	+4	+6 dB
0A	+3	+4.5 dB
09	+2	+3 dB
08	+1	+1.5 dB
07	0	0 dB
06	-1	-1.5 dB
05	-2	-3 dB
04	-3	-4.5 dB
03	-4	-6 dB
02	-5	-7.5 dB
01	-6	-9 dB
00	-7	-10.5 dB

---

## High Resolution Mode

This mode enhances edges and produces higher definition images.

---

## Aperture Control

Aperture control is a function which adjusts the enhancement of the edges of objects in the picture. There are 16 levels of adjustment, starting from “no enhancement.” When shooting text, this control may help by making them sharper.

---

## Back Light Compensation

When the background of the subject is too bright, or when the subject is too dark due to shooting in the AE mode, back light compensation will make the subject appear clearer.

---

## Noise Reduction

The NR (Noise Reduction) function removes noise (both random and non-random) to provide clearer images.

This function has six steps: levels 1 to 5, plus off.

The NR effect is applied in levels based on the gain, and this setting value determines the limit of the effect. In bright conditions, changing the NR level will not have an effect.

---

## High Sensitivity Mode

In this mode, higher sensitivity gain is applied as standard gain increases, reaching a gain level at MAX gain of up to 4x the standard gain. In such cases, however, there will be a high volume noise in the image.

---

## Gamma Mode

In this mode, the gamma can be set to ON/OFF.

0: Standard

1: OFF

---

## Image Stabilizer

You can set this function to ON or OFF. When set to ON, you can obtain steadier images if vibration is present. This stabilizer is effective for vibration frequencies around 10 Hz. This function utilizes digital zoom; therefore, the angle of view and resolution of images may be affected. However, image sensitivity is retained.

OFF: The image stabilizer function is not effective operations.

ON: The image stabilizer function is effective operations.

HOLD: The image stabilizer function is not effective operations. (The same shift of field angle as ON can be used.)

### Notes

- The image stabilizer function is not effective during pan/tilt operations. It may take some time for the image to stabilize after performing pan/tilt operations.
- If the image stabilizer function is enabled, it may take some time for the image to stabilize after turning on the power of the camera.
- Depending on the installation conditions, the image stabilizer may not be effective.
- When the image stabilizer function is set to ON or HOLD, the field angle is shifted to the direction in which the subject appears larger.
- The image stabilizer may not be effective in an installation environment where high frequency vibration is present. In this case, set the image stabilizer function to OFF.
- The image stabilizer function is enabled only when the Video Latency is set to NORMAL.

---

## Auto Slow Shutter On/Off

When set to “On,” the slow shutter functions automatically when the light darkens. This setting is available only when the AE mode is set to “Full Auto.” The default setting is “Auto Slow Shutter Off.”

---

## Low-Illumination Chroma Suppress Mode

You can configure a chroma suppress mode for low-illumination conditions. This can be useful when color noise is particularly noticeable in such conditions. Four levels (disabled and three levels) are available for the low-illumination chroma suppress mode.

---

## ICR (IR Cut-Removable) Mode

The IR Cut-Filter can be disengaged, by which the sensitivity in the infrared range is increased, allowing the camera to capture the image in darker area. When the auto ICR mode is set to ON, the image becomes black and white.

---

## Color Gain

You can configure the color gain. Use this setting when bright color is particularly important.

The initial setting 100% (4h) can be set to range from approx. 60% (0h) to 200% (Eh) with 15 stages.

---

## Color Phase

You can configure green, yellow, red, magenta, blue and cyan individually.

The initial setting 0 degrees (7h) is adjustable between approx. -14 degrees (0h) to +14 degrees (Eh), in 15 increments.

---

## Auto ICR Mode

Auto ICR Mode automatically switches the settings needed for attaching or removing the IR Cut Filter. With a set level of darkness, the IR Cut Filter is automatically disabled (ICR ON), and the infrared sensitivity is increased. With a set level of brightness, the IR Cut Filter is automatically enabled (ICR OFF). Also, on systems equipped with an IR light, the internal data of the camera is used to make the proper decisions to avoid malfunctions.

Auto ICR Mode operates with the AE Full Auto setting.

### When Auto Slow Shutter is Off (initial setting)

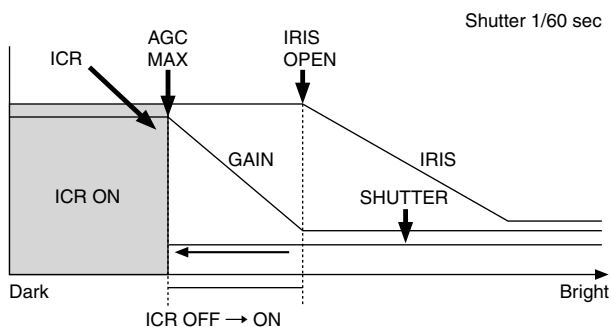

### When Auto Slow Shutter is On

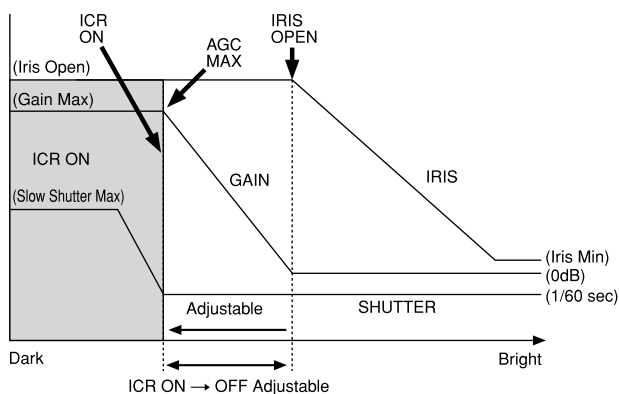

#### Note

Depending on the information such as brightness, etc., in the ON/OFF settings condition, a malfunction may occur when the subjects largely consisting of blue and green colors are taken.

## Camera ID

The ID can be set up to 65,536 (0000 to FFFF). As this will be memorized in the nonvolatile memory inside, data will be saved.

## Picture Effect

It consists of the following functions.

- **Neg. Art:** Negative/Positive Reversal
- **Black & White:** Monochrome Image

## PAN/TILT SLOW mode

When this function is set to ON, the PAN/TILT movement slows down, allowing you to easily shoot the subject that moves slowly.

#### Note

The low-speed motion image may appear to be shaking depending on the zoom factor.

## Video Latency setting

When the Video Latency is set to LOW, the latency until the shot image is output from the camera is shortened.

#### Note

While it is set to LOW, the digital zoom and image stabilizer functions are disabled. The field angle may be narrowed by Video Format. The image distortion may be remarkable depending on the magnification.

## Check for influence of installation environment on infrared remote commander operation

The supplied infrared remote commander may not operate, only occasionally, in the vicinity of the inverter lighting device. In this case, it is possible that the camera is installed in a place where the infrared remote commander cannot stably receive light due to the emission of light from the lighting device.

In either the DC power or VISCA communication, it is judged whether or not the infrared remote commander is under the installation environment where it can receive signal during the initialization process performed after the power of camera is turned on. The result of this judgment can be obtained using the IR\_ConditionInq command. (See page 41.)

If the installation environment is judged to be unstable for operating the infrared remote commander, try to take such measures as to install this unit in a place away from the lighting device having the influence, and so on.

---

## Others

### STANDBY

Sends the power off command. Or when the power is turned off using the infrared remote commander, the camera becomes STANDBY state. In the STANDBY state, the camera can accept only the VISCA Commands and the POWER ON of the infrared remote commander, and the video signal output and other operations are stopped.

### I/F Clear

Clears the Command buffer of the camera.  
The buffer is cleared even during the power on state using the control software.

### Address Set

VISCA is a protocol, which supports a daisy chain of up to seven connected cameras via RS-232 interface. In such cases, the address set command can be used to assign addresses from 1 to 7 to each of the seven cameras, allowing you to control the seven cameras with the same personal computer. Be sure to use the address set command to set the address whenever a camera is connected for the first time.

### Memory (Preset)

Using the preset function, 16 sets of camera shooting conditions can be stored and recalled.  
This function allows you to achieve the desired status instantly, even without adjusting the following items each time.

- Pan/Tilt Position
- Zoom Position
- Digital Zoom On/Off
- Focus Auto/Manual
- Focus Position
- AE Mode
- Shutter control parameters
- Bright Control
- Iris control parameters
- Gain control parameters
- Exposure Compensation On/Off
- Exposure Level
- Backlight Compensation On/Off
- Auto Slow Shutter On/Off
- White Balance Mode
- R/B Gain
- Aperture Control
- ICR On/Off
- WD Parameter
- Defog On/Off

The settings stored using this function are recalled when the power is turned on.

*For setting items, see the “Initial Settings and Preset” section on page 17.*

#### Note

Rewriting of memory is not unlimited. Be careful to avoid using the memory area for such as unnecessary tasks as rewriting the contents of the memory for every operation.



# Initial Settings and Preset

- The initial values are the factory settings.
- When the power is turned on, this unit starts operation with the settings stored in preset 1.
- In “Preset 1 to 16”, the items that are preserved even after the power from the camera is turned off are indicated by a circle (○), and the items that are not preserved are indicated by a cross (×).
- When you send the CAM Memory Reset command, or select and press one of POSITION1 to 6 while pressing the PRESET button using the infrared remote commander, the selected number is set as initial value.
- The preset 1 is the CAM Memory number “0” in the VISCA command. The preset 2 to 16 are the CAM Memory number “1 to 15” in the VISCA command.

Mode/Position setting	Initial settings	Preset 1	Preset 2 to 16
Pan/Tilt Position	Home position	○	○
Pan/Tilt Limit Position	Maximum range of movement	○	×
Zoom Position	Wide end	○	○
D-Zoom On/Off	On	○	○
Focus Position	—	○	○
Focus Auto/Manual	Auto	○	○
Near Limit Setting	D000h (30 cm)	○	×
AF Sensitivity	Normal	○	×
AF Mode	Normal	○	×
AF Run Time	5 sec	○	×
AF Interval	5 sec	○	×
WB Mode	Auto	○	○
WB Data (Rgain, Bgain)	—	○	○
One Push WB Data	—	○	×
AE Mode	Full Auto	○	○
WD Mode	Off	○	○
Auto Slow Shutter Mode	Off	○	○
Shutter Position	—	○	○
Iris Position	—	○	○
Gain Position	—	○	○
Bright Position	—	○	○
Exposure Compensation On/Off	Off	○	○
Exposure Compensation Amount	±0	○	○
BackLight On/Off	Off	○	○
Aperture Level	0Ah	○	○
High Resolution Mode On/Off	Off	○	×
Picture Effect	Off	○	×
ICR On/Off	Off	○	○
Auto ICR On/Off	Off	○	×
Auto ICR Threshold Level	0Eh	○	×
Image Stabilizer On/Off/Hold	Off	○	×
High Sensitivity Mode On/Off	Off	○	×
Gamma	0:standard	○	×
Defog On/Off	Off	○	○
NR Level	3	○	×
Gain Limit	—	○	×
Low-Illumination Chroma Suppress	2h (Middle)	○	×
Color Gain	4h (100%)	○	×
Color Hue	7h (0degrees)	○	×
IR_Receive On/Off	On	○	×
IR_Receive Return On/Off	Off	○	×
INFORMATION DISPLAY	On	○	×

A circle “○” in this column signifies that the data is preserved.

A cross “×” signifies that the data IS NOT preserved.

## Notes

- The execution of memory to the preset is limited.
- When turning the power off and on again, if you want to reflect the camera conditions and pan/tilt position that are set before the power is turned off, store the settings in POSITION1.
- The setting or deleting of memory to/from preset 1 takes approx. 2 seconds longer than other channels.
- In CameraID, the data is stored regardless of the preset.
- When ImageFlip is executed, all presets are reset to the initial value.

# Mode Condition

## Basic settings

Command	Mode	Power Off <sup>1)</sup>	Power On						
			IFC <sup>2)</sup>	Initializing <sup>3)</sup>	During displaying the menu	Memory Command	OnePushWB	VideoFormatChange	Pan-TiltReset
Address Set		Yes	Yes	Yes	Yes	Yes	Yes	Yes	Yes
IF_Clear		Yes <sup>7)</sup>	Yes <sup>7)</sup>	Yes <sup>7)</sup>	Yes <sup>7)</sup>	Yes <sup>7)</sup>	Yes <sup>7)</sup>	Yes <sup>7)</sup>	Yes <sup>7)</sup>
CAM_Power On		Yes	No	Yes	No	Yes	Yes	No	Yes
CAM_Power Off		Yes	No	Yes	No	Yes	Yes	No	Yes
IR_Receive On/Off		No	No	Yes <sup>4)</sup> 6)	No	No	No	No	Yes
IR_ReceiveReturn On/Off		No	No	Yes <sup>6)</sup>	No	No	No	No	Yes
CAM_VersionInq		Yes	Yes <sup>5)</sup>	Yes	Yes	Yes	Yes	Yes	Yes
CAM_PowerInq		Yes	Yes	Yes	Yes	Yes	Yes	Yes	Yes
InquiryCommand		No	No	Yes <sup>6)</sup>	No	No	No	No	Yes

1) DC power is being supplied, but the camera has been turned off by a VISCA command.

2) The period from the time IF Clear is sent, until the Reply Packet is returned.

3) The period from the time DC power is turned on or the camera is turned on via a VISCA command, and the camera subsequently finishes the pan/tilt reset operation and stops at the Home position, until the video signal is output. Or the period from the time the CAM Power ON command is sent, until Completion is returned.

4) The camera does not receive the operation sent from the Infrared Remote Commander.

5) Commands can be executed after the pan/tilt movement has been started. Before that, camera movement may be inconsistent.

6) When the menu display is updating, operation is not possible.

7) Although the command is received, it is not executed.

## Output settings

Command	Mode	Power Off	Power On									
			IFC	Initializing	PanTilt	PanTilt ABS	PanTilt Rel	ZoomDirect	Focus Direct	Recall	During displaying the menu	OnePush WB
CAM_LowLatency		No	No	No	No	No	No	No	No	No	No	No
CAM_VideoFormatChange (Execution of the VISCA command from user during the VISCA mode)		No	No	No	No	No	No	No	No	No	Yes <sup>1)</sup>	No

1) The Video Format state of MENU is not updated. Close MENU once, and then display it again. Other commands are not received during the execution of Format Change and Low Latency.

## Zoom/Focus

Command	Mode	Power Off <sup>1)</sup>	Power On						Memory Recall
			IFC <sup>2)</sup>	Initializing <sup>3)</sup>	Zoom Direct	Focus Direct	AF ON	During displaying the menu	
CAM_Zoom Tele/Wide/Stop [VISCA]		No	No	No	Yes	Yes	Yes <sup>4)</sup>	No	
CAM_Zoom Tele/Wide/Stop [Infrared Remote Commander]		No	No	No	Yes	Yes	Yes <sup>4)</sup>	No	
CAM_Zoom Direct		No	No	Yes	Yes	Yes	Yes <sup>4)</sup>	No	
D-Zoom Limit		No	No	No	Yes	Yes	Yes <sup>4)</sup>	No	
CAM_Focus Far/Near/Stop [VISCA]		No	No	Yes	No	No	Yes <sup>4)</sup>	No	
CAM_Focus Far/Near/Stop [Infrared Remote Commander]		No	No	Yes	Yes	No	Yes <sup>4)</sup>	No	
CAM_Focus Direct		No	No	Yes	Yes	No	Yes <sup>4)</sup>	No	
CAM_Focus Mode (Auto/Manual)		No	No	Yes	No	Yes	Yes <sup>4)</sup>	No	
CAM_Focus One Push Trigger		No	No	Yes	No	No	Yes <sup>4)</sup>	No	
CAM_Focus Infinity		No	No	Yes	No	Yes	Yes <sup>4)</sup>	No	
CAM_Focus Near Limit		No	No	Yes	No	Yes	Yes <sup>4)</sup>	No	
AF Sensitivity Normal/Low		No	No	Yes	Yes	Yes	Yes <sup>4)</sup>	No	
AF Mode Norm/Interval/Zoom		No	No	Yes	Yes	Yes	Yes <sup>4)</sup>	No	
AF Activation Time/Interval Setting		No	No	Yes	Yes	Yes	Yes <sup>4)</sup>	No	

1) DC power is being supplied, but the camera has been turned off by a VISCA command.

2) The period from the time IF Clear is sent, until the Reply Packet is returned.

3) The period from the time DC power is turned on or the camera is turned on via a VISCA command, and the camera subsequently finishes the pan/tilt reset operation and stops at the Home position, until the video signal is output. Or the period from the time the CAM Power ON command is sent, until Completion is returned.

4) When the menu display is updating, operation is not possible.

## White Balance

Command	Mode	Power Off <sup>1)</sup>	IFC <sup>2)</sup>	Initializing <sup>3)</sup>	Power On					Memory Recall		
					White balance mode			During displaying the menu				
					Auto	Indoor	Outdoor	One Push	Manual	ATW		
CAM_WB Auto/Indoor/Outdoor/OnePushWB/Manual/ATW		No	No	No	Yes	Yes	Yes	Yes	Yes	Yes	Yes <sup>4)</sup>	No
CAM_WB One Push Trigger		No	No	No	No	No	No	Yes <sup>5)</sup>	No	No	Yes <sup>4)</sup>	No
CAM_WB R(B) Gain Reset/Up/Down/Direct		No	No	No	No	No	No	No	Yes	No	Yes <sup>4)</sup>	No

1) DC power is being supplied, but the camera has been turned off by a VISCA command.

2) The period from the time IF Clear is sent, until the Reply Packet is returned.

3) The period from the time DC power is turned on or the camera is turned on via a VISCA command, and the camera subsequently finishes the pan/tilt reset operation and stops at the Home position, until the video signal is output. Or the period from the time the CAM Power ON command is sent, until Completion is returned.

4) When the menu display is updating, operation is not possible.

5) Commands are ignored during a One Push AWB operation.

# Exposure

Command	Mode	Power Off <sup>1)</sup>	IFC <sup>2)</sup>	Initializing <sup>3)</sup>	Power On							Memory Recall	
					Full Auto WIDE D Off	Full Auto WIDE D Low/Mid/High	Bright	Shutter Pri	Iris Pri	Manual	During displaying the menu		
CAM_AE		No	No	No	Yes	No	Yes <sup>4)</sup>	Yes	Yes	Yes	Yes	Yes <sup>5)</sup>	No
Full Auto/Manual/Shutter Pri/Iris Pri/Spot Light		No	No	No	Yes	No	Yes	Yes	Yes	No	No	Yes <sup>5)</sup>	No
CAM_AE Bright		No	No	No	No	No	No	No	No	Yes	Yes	Yes <sup>5)</sup>	No
CAM_Slow Shutter Limit ON/OFF		No	No	No	No	No	No	No	No	No	No	Yes <sup>5)</sup>	No
CAM_Shutter Reset/Up/Down/Direct		No	No	No	No	No	No	No	No	Yes	Yes	Yes <sup>5)</sup>	No
CAM_Iris Reset/Up/Down/Direct		No	No	No	No	No	No	No	No	Yes	Yes	Yes <sup>5)</sup>	No
CAM_Gain Reset/Up/Down/Direct		No	No	No	No	No	Yes	Yes	No	No	No	Yes <sup>5)</sup>	No
CAM_Bright/Up/Down/Direct		No	No	No	Yes	Yes	Yes	Yes	Yes	Yes	Yes	Yes <sup>5)</sup>	No
CAM_ExComp On/Off		No	No	No	Yes	Yes	Yes	Yes	Yes	Yes	Yes	Yes <sup>5)</sup>	No
CAM_ExComp Reset/Up/Down/Direct <sup>6)</sup>		No	No	No	Yes	Yes	Yes	Yes	Yes	Yes	Yes	Yes <sup>5)</sup>	No
CAM_Backlight On/Off		No	No	No	Yes	Yes	No	No	No	No	No	Yes <sup>5)</sup>	No
CAM_WIDE D Off/Low/Mid/High		No	No	No	Yes	Yes	No	No	No	No	No	Yes <sup>5)7)</sup>	No
CAM_Defog		No	No	No	Yes	Yes	Yes	Yes	Yes	Yes	Yes	Yes <sup>7)</sup>	No

1) DC power is being supplied, but the camera has been turned off by a VISCA command.  
 2) The period from the time IF Clear is sent, until the Reply Packet is returned.  
 3) The period from the time DC power is turned on or the camera is turned on via a VISCA command, and the camera subsequently finishes the pan/tilt reset operation and stops at the Home position, until the video signal is output. Or the period from the time the CAM Power ON command is sent, until Completion is returned.  
 4) Yes: Only when the camera changes to BRIGHT mode from Full Auto or SHUTTER Pri mode.  
 5) When the menu display is updating, operation is not possible.  
 6) No: This is not allowed when EX-COMP is set to OFF.  
 7) This can be changed only when the exposure control mode is Full Auto.

## Effect

Command	Mode	Power Off <sup>1)</sup>	Power On			
			IFC <sup>2)</sup>	Initializing <sup>3)</sup>	During displaying the menu	Memory Recall
CAM_Aperture Reset/Up/Down/Direct		No	No	No	Yes <sup>4)</sup>	No
Display info. (ON/OFF)		No	No	No	Yes <sup>4)</sup>	No
CAM_PictureEffect OFF/Neg.Art/B&W		No	No	No	Yes <sup>4)</sup>	No
CAM_ICR ON/OFF		No	No	No	Yes <sup>4)</sup>	No
CAM_AutoICR ON/OFF/Threshold		No	No	No	Yes <sup>4)</sup>	No
CAM_HR ON/OFF		No	No	No	Yes <sup>4)</sup>	No
CAM_NR		No	No	No	Yes <sup>4)</sup>	No
CAM-ChromaSuppress		No	No	No	Yes <sup>4)</sup>	No
CAM_ColorGain		No	No	No	Yes <sup>4)</sup>	No
CAM_ColorHue		No	No	No	Yes <sup>4)</sup>	No
CAM_Stabilizer		No	No	No	Yes <sup>4)</sup>	No

1) DC power is being supplied, but the camera has been turned off by a VISCA command.

2) The period from the time IF Clear is sent, until the Reply Packet is returned.

3) The period from the time DC power is turned on or the camera is turned on via a VISCA command, and the camera subsequently finishes the pan/tilt reset operation and stops at the Home position, until the video signal is output. Or the period from the time the CAM Power ON command is sent, until Completion is returned.

4) When the menu display is updating, operation is not possible.

# Pan/Tilt

Mode		Power On											Position detection error				
		Pan/Tilt normal status															
Command	Power Off <sup>1)</sup>	IFC <sup>2)</sup>	Initia- lizing <sup>3)</sup>	Zoom (Direct)	Focus (Direct)	Pan/tilt movement according to the command <sup>4)</sup>		Absolute Position execution	Relative Position execution	Home execution		Reset execution		Memory Recall		During displaying the menu	
						VISCA	Infrared Remote Commander			VISCA	Infrared Remote Commander	VISCA	Infrared Remote Commander	VISCA	Infrared Remote Commander		VISCA
Pan-tiltDrive Up/Down/ Left/ Right/UpLeft/ UpRight/ DownLeft/ DownRight	No	No	No	Yes	Yes	Yes	Yes	No	No	No	No	No	No	No	No	Yes <sup>10)</sup>	Yes <sup>8)</sup>
Pan-tiltDrive AbsolutePosition	No	No	No	Yes	Yes	No	Yes	No	No	No	No	No	No	No	No	Yes <sup>5)</sup>	No
Pan-tiltDrive RelativePosition	No	No	No	Yes	Yes	No	No	No	No	No	No	No	No	No	No	Yes <sup>5)</sup>	Yes
Pan-tiltDrive Home	No	No	No	Yes	Yes	No	No	No	No	Yes	No	No	No	No	No	Yes	No
Pan-tiltDrive Reset	No	No	No	Yes	Yes	No	No	No	No	No	No	No	No	No	No	Yes <sup>5)</sup>	Yes
Pan-tiltLimitSet LimitClear	No	No	No	Yes	Yes	Yes <sup>9)</sup>	Yes <sup>9)</sup>	No	No	No	No	No	No	No	No	Yes <sup>5)</sup>	No
Memory Set	No	No	No	No	No	No	No	No	No	No	No	No	No	No	No	No	No
Memory Reset	No	No	No	No	No	No	No	No	No	No	No	No	No	No	No	No	No
Memory Recall	No	No	No	No	No	No	No	No	No	No	No	No	No	Yes	Yes	No	No
Pan-tiltSetSlowPanTilt	No	No	No	Yes	Yes	Yes <sup>9)</sup>	Yes <sup>9)</sup>	No	No	No	No	No	No	No	No	Yes	No

1) DC power is being supplied, but the camera has been turned off by a VISCA command.

2) The period from the time IF Clear is sent, until the Reply Packet is returned.

3) The period from the time DC power is turned on or the camera is turned on via a VISCA command, and the camera subsequently finishes the pan/tilt reset operation and stops at the Home position, until the video signal is output.

4) The pan/tilt operation works by Pan-tiltDrive Up/Down/Left/Right/UpLeft/UpRight/DownLeft/DownRight commands.

5) When the menu display is updating, operation is not possible.

6) Yes: while the camera operates in Tele/Wide zoom mode.

7) Yes: while the camera operates in Far/Near focus mode.

8) Yes: only for movements away from the direction where a position detection error has been recognized.

9) The setting is reflected after the drive has stopped.

10) Although Ack/Comp is returned, the pan/tilt operation is not performed.

# Command List

## VISCA<sup>1)</sup> RS-232/RS-422 Commands

Use of RS-232/RS-422 control software based upon this command list may cause malfunction or damage to hardware and software. Sony Corporation is not liable for any such damage.

### Overview of VISCA

In VISCA, the device outputting the commands, for example, a computer, is called the controller, while the device receiving the commands, such as this unit, is called the peripheral device. In VISCA, up to seven peripheral devices can be connected to one controller using communication conforming to the RS-232/RS-422 standard. The parameters of RS-232/RS-422 are as follows.

- Communication speed: 9600 bps/38400 bps
- Data bits : 8
- Start bit : 1
- Stop bit : 1
- Non parity

Flow control using XON/XOFF and RTS/CTS, etc., is not supported.

Peripheral devices are connected in a daisy chain. As shown in Fig. 1, the actual internal connection is a one-direction ring, so that messages return to the controller via the peripheral devices. The devices on the network are assigned addresses.

The device address is assigned to each device on the network. The address of the controller is fixed at 0.

Each VISCA equipment has VISCA IN and VISCA OUT connectors. Set the DTR input (the S output of the controller) of VISCA IN to H when controlling VISCA equipment from the controller.

#### Note

When connecting in a daisy chain using this unit, set the VISCA/LAN switch, RS-232/RS-422 SELECT switch, and BAUD RATE SELECT switch correctly.

In case that any device having different setting is connected in a daisy chain, the devices do not operate correctly.

Fig. 1 VISCA daisy chain connection

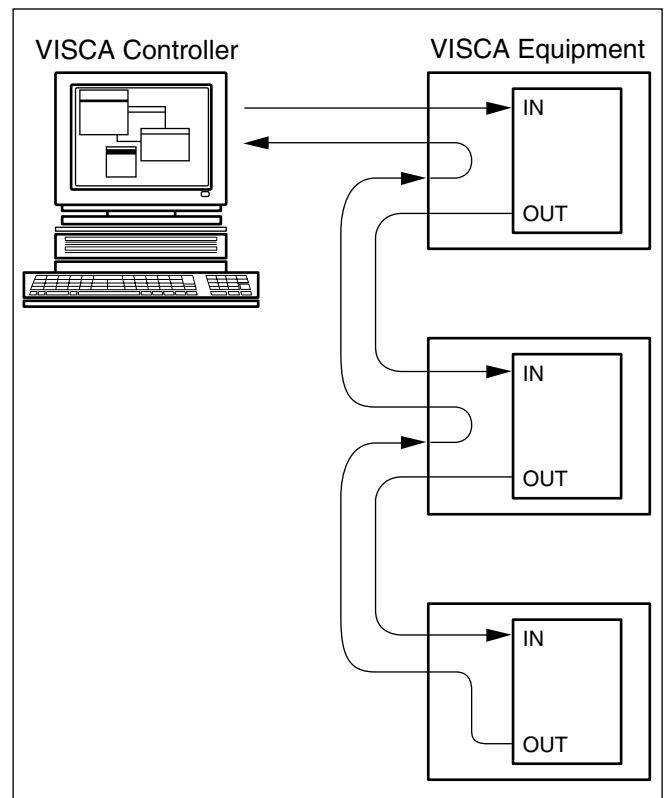

<sup>1)</sup> VISCA is a protocol developed by Sony for controlling a consumer's camcorder. "VISCA" is a trademark of Sony Corporation.

# VISCA Communication Specifications

## VISCA packet structure

The basic unit of VISCA communication is called a packet (Fig. 2). The first byte of the packet is called the header and comprises the sender's and receiver's addresses. For example, the header of the packet sent to the SRG assigned address 1 from the controller (address 0) is 81h in hexadecimal. The packet sent to the SRG assigned address 2 is 82h. In the command list, as the header is 8X, input the address of the SRG to X. The header of the reply packet from the SRG assigned address 1 is 90h. The packet from the SRG assigned address 2 is A0h.

Some of the setting commands for SRG can be sent to all devices at one time (broadcast)\*. In the case of broadcast, the header should be 88h in hexadecimal.

When the terminator is FFh, it signifies the end of the packet.

\* The broadcast function is not available for VISCA over IP.

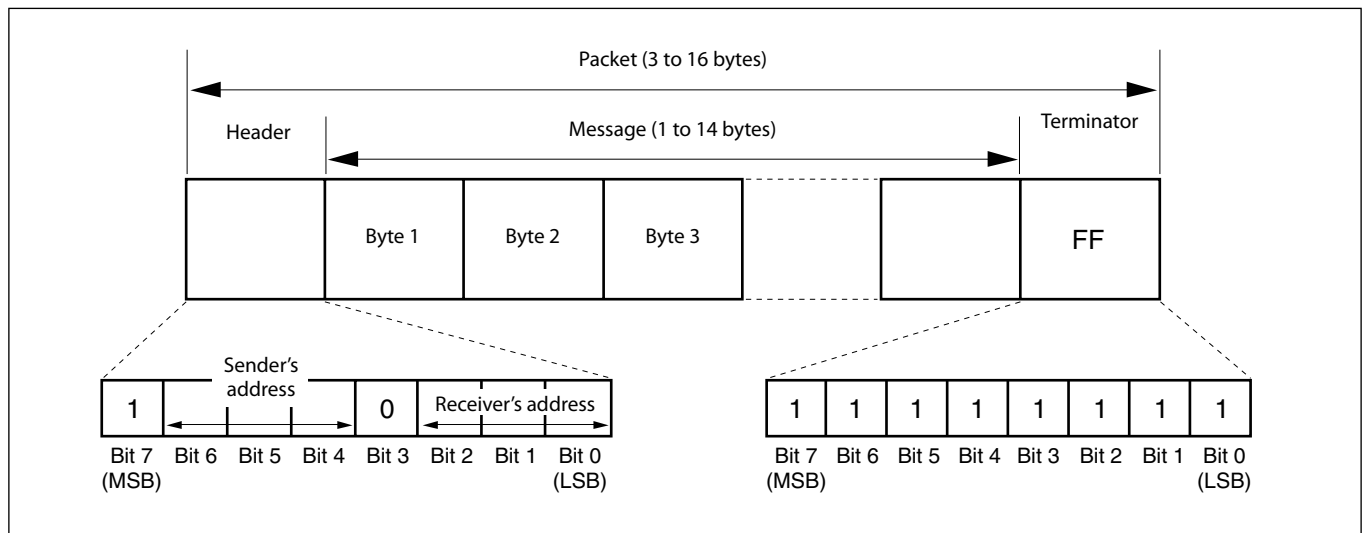

Fig. 2 Packet structure

**Note**

Fig. 2 shows the packet structure, while Fig. 3 shows the actual waveform. Data flow will take place with the LSB first.

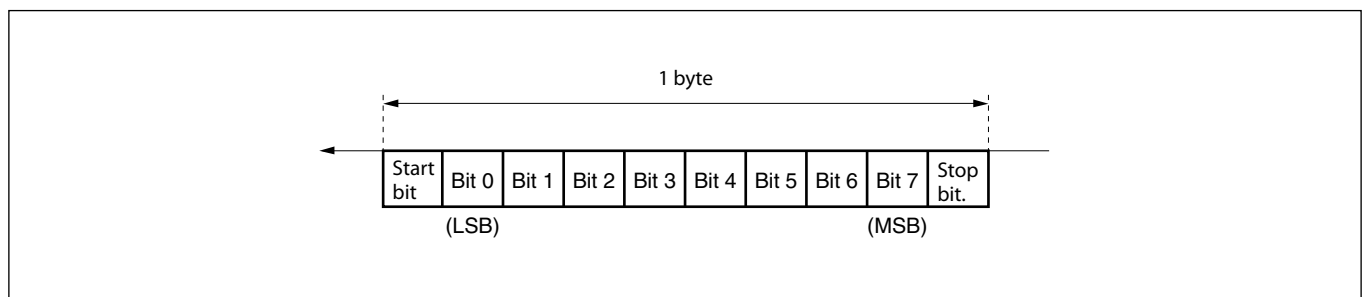
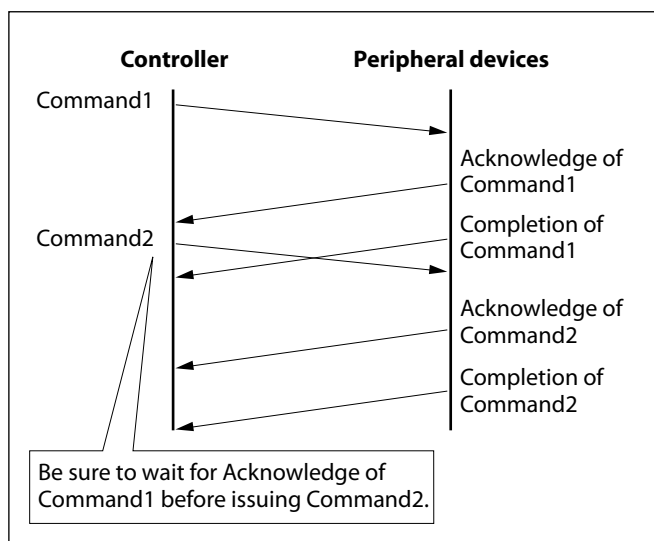

Fig. 3 Actual waveform for 1 byte.



## Timing Chart

If two or more commands are to be sent successively, wait for a reply command (an Acknowledge or error message for a general command, and an inquiry packet for an inquiry command) of the previous command to be received before sending the next command.



## Command and inquiry

### ● Command

Sends operational commands to this unit.

### ● Inquiry

Used for inquiring about the current state of this unit.

	Command Packet	Note
Inquiry	8X QQ RR ... FF	QQ <sup>1)</sup> = Command/Inquiry, RR <sup>2)</sup> = category code

<sup>1)</sup> QQ = 01 (Command), 09 (Inquiry)

<sup>2)</sup> RR = 00 (Interface), 04 (camera 1), 06 (Pan/Tilter)

X = 1 to 7: Address of this unit in the daisy chain\*

\* Locked to "X = 1" for VISCA over IP.

For actual values to be sent, see Command Lists or Inquiry Command Lists.

## Responses for commands and inquiries

### ● Acknowledge message

A message returned by this unit when it receives a command. No Acknowledge message is returned for an inquiry, cancel, or device setting command.

### ● Completion message

A message returned by this unit when the execution of command or inquiry is completed. In the case of inquiry commands, reply data for the inquiry is contained after the 3rd byte of the packet. If the Acknowledge message is omitted, the socket number will contain 0.

	Reply Packet	Note
Acknowledge	X0 4Y FF	Y = socket number
Completion (Commands)	X0 5Y FF	Y = socket number
Completion (Inquiries)	X0 5Y ... FF	Y = socket number

X = 9 to F: Address of this unit specified when the command or inquiry is executed + 8.\*

\* Locked to "X = 9" for VISCA over IP.

### ● Error message

When a command could not be executed or failed, an error message is returned instead of an Acknowledge message. In some commands (such as zoom) in which the process is not completed immediately after the Acknowledge message, an error message may be returned after an Acknowledge message. When an inquiry command could not be executed or failed, an error message is returned instead of a completion message.

Error Packet	Description
X0 6Y 01 FF	Message length error
X0 60 02 FF	Syntax Error
X0 60 03 FF	Command buffer full
X0 6Y 04 FF	Command canceled
X0 6Y 05 FF	No socket (to be canceled)
X0 6Y 41 FF	Command not executable

X = 9 to F: Address of this unit specified when the command is executed + 8, Y = socket number\*

\* Locked to "X = 9" for VISCA over IP.

---

## Socket number

This unit has two sets of sockets (buffers) for commands, so that up to two commands including the commands currently being executed can be received. When this unit receives commands, it notifies the sender which socket was used, using the socket number of the Acknowledge message. As each of the completion message and error message also has a socket number, you can identify which command has ended.

When sending the commands continuously, be sure to wait until an Acknowledge message or error message of the first command is returned, then send the next command. (Otherwise, it is impossible to identify to which command the socket number belongs.)

Even when two sockets are being used, the device setting commands and some inquiry messages can be executed. The Acknowledge message is not returned for these commands and inquiries, and only the completion message of socket number 0 is returned.

---

## Command execution cancel

To cancel a command which has already been sent, send a Cancel command as the next command.

	Cancel Packet	Note
Cancel	8X 2Y FF	Y = socket number
X = 1 to 7: Address of this unit in the daisy chain, Y = socket number*		
* Locked to "X = 1" for VISCA over IP.		

Error message "Command canceled" will be returned for this command, but this is not a fault. It indicates that the command has been canceled.

## VISCA Device Setting Command

Before starting control of this unit, be sure to send the Address command and the IF\_Clear command using the broadcast function.

---

### For VISCA network administration

- **Address\***  
Sets an address of a peripheral device. Use when initializing the network, and receiving the following network change message.  
\* Not available for VISCA over IP.
- **Network Change\***  
Sent from the peripheral device to the controller when a device is removed from or added to the network. The address must be re-set when this message is received.  
\* Not available for VISCA over IP.

	Packet	Note
Address	88 30 01 FF	Always broadcasted.
Network Change	X0 38 FF	
X = 9 to F: SRG address + 8		

---

### VISCA interface command

- **IF\_Clear**  
Clears the socket in the SRG.  
When cleared, the operation currently being executed is not guaranteed.

	Command Packet	Reply Packet	Note
IF_Clear	8X 01 00 01 FF	Z0 50 FF	
IF_Clear (broadcast) <sup>1)</sup>	88 01 00 01 FF	88 01 00 01 FF	
X = 1 to 7: Address of this unit in the daisy chain (For inquiry packet) <sup>2)</sup>			
Z = 9 to F: Address of this unit that issued IF_Clear command +8 (For reply packet) <sup>3)</sup>			

<sup>1)</sup> The broadcast function is not available for VISCA over IP.

<sup>2)</sup> Locked to "X = 1" for VISCA over IP.

<sup>3)</sup> Locked to "X = 9" for VISCA over IP.

## VISCA interface and inquiry

### ● CAM\_VersionInq

Returns information on the VISCA interface.

Inquiry	Inquiry Packet	Reply Packet	Description
CAM_VersionInq	8X 09 00 02 FF	Y0 50 GG GG HH HH JJ JJ KK FF	GGGG = Vender ID (0001: Sony) HHHH = Model ID 0513: SRG-300H JJJJ = ROM revision KK = Maximum socket # (02)

X = 1 to 7: Address of this unit in the daisy chain (For inquiry packet)<sup>1)</sup>

Y = 9 to F: Address of this unit that issued the inquiry +8 (For reply packet)<sup>2)</sup>

<sup>1)</sup> Locked to "X = 1" for VISCA over IP.

<sup>2)</sup> Locked to "Y = 9" for VISCA over IP.

## VISCA Command/Acknowledge Protocol

Command	Command Message	Reply Message	Comments
General Command	81 01 04 38 02 FF (Example)	90 41 FF (Acknowledge) +90 51 FF (Completion) 90 42 FF 90 52 FF	Returns Acknowledge when a command has been accepted, or Completion when a command has been executed.
	81 01 04 38 FF (Example)	90 60 02 FF (Syntax Error)	Accepted a command which is not supported or a command lacking parameters.
	81 01 04 38 02 FF (Example)	90 60 03 FF (Command Buffer Full)	Could not accept the command as there are two commands currently being executed.
	81 01 04 08 02 FF (Example)	90 61 41 FF (Command Not Executable) 90 62 41 FF	Could not execute the command in the current mode.
Inquiry Command	81 09 04 38 FF (Example)	90 50 02 FF (Completion)	Does not return Acknowledge.
	81 09 05 38 FF (Example)	90 60 02 FF (Syntax Error)	Accepted an incompatible command.
Command Cancel	81 22 FF (Example)	90 62 04 FF (Command Canceled)	Returned when the command of the socket specified is canceled. Completion for the command canceled is not returned.
		90 62 05 FF (No Socket)	Returned when the command of the specified socket has already been completed or when the socket number specified is wrong.
Address Set <sup>1)</sup>	88 30 01 FF	88 30 02 FF	The device address number plus 1 is returned.
IF_Clear (Broadcast) <sup>1)</sup>	88 01 00 01 FF	88 01 00 01 FF	The same command is returned.
IF Clear (for device address 1)	81 01 00 01 FF (Example)	90 50 FF (Completion)	Acknowledge is not returned for this command.

<sup>1)</sup> Not available for VISCA over IP.

## VISCA Camera-Issued Messages

### Acknowledge/Completion Messages

Command	Command Message	Comments
Acknowledge	z0 4y FF (y: Socket No.)	Returned when the command is accepted.
Completion	z0 5y FF (y: Socket No.)	Returned when the command has been executed.

z = Address of device that issued the message + 8 (Locked to "z = 9" for VISCA over IP.)

### Error Messages

Command	Command Message	Comments
Syntax Error	z0 60 02 FF	Returned when the format is different or when a command with illegal parameters is accepted.
Command Buffer Full	z0 60 03 FF	Could not accept a command that is received while two commands are currently being executed (two sockets have been used).
Command Canceled	z0 6y 04 FF (y: Socket No.)	Returned when a command which is being executed in a socket specified by the cancel command is canceled. The completion message for the command is not returned.
No Socket	z0 6y 05 FF (y: Socket No.)	Returned when no command is executed in a socket specified by the cancel command, or when an invalid socket number is specified.
Command Not Executable	z0 6y 41 FF (y: Socket No.)	Returned when a command cannot be executed due to current conditions. For example, when a command for controlling the manual focus is received during the auto focus mode.

z = Address of device that issued the error + 8 (Locked to "z = 9" for VISCA over IP.)

### Network Change Message\*

Command	Command Message	Comments
Network Change	z0 38 FF	Issued when power is supplied to the camera.

\* Not available for VISCA over IP.

## VISCA over IP

### Overview of VISCA over IP

VISCA over IP allows you to control this unit from the controller with the IP communication function via the LAN by using VISCA.

You can connect up to 5 controllers simultaneously on the network.

The communication specifications of VISCA over IP are as follows:

- **Interface**

RJ-45 10Base-T/100Base-TX (automatically discrimination)

- **Internet protocol**

IPv4

- **Transport protocol**

UDP

- **IP address**

Set by the IP card setting command

- **Port address**

52381

- **Delivery confirmation/Retransmission control**

Depends on the application

In this section, the device outputting commands, for example, a computer, is called the controller, and this unit and the devices connected to the same LAN are called the peripheral device. In the connection using RS-232/RS-422, the controllers and peripheral devices are connected to a one-direction ring. On the IP communication connection, the controllers and peripheral devices are connected by star type through a LAN.

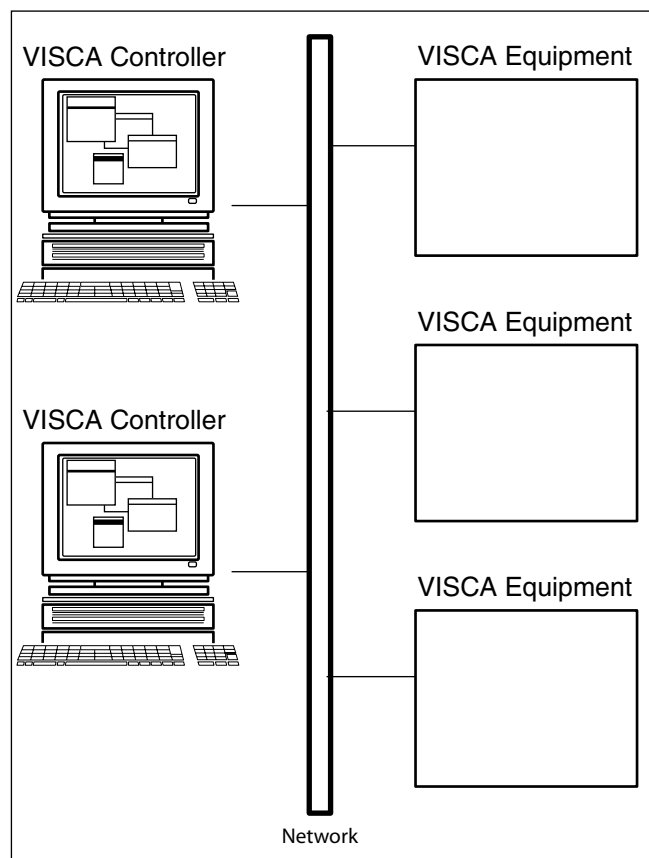

**IP communication connection**

While the IP communication connection, the address of each device cannot be set in the VISCA message as it is because the controllers and peripheral devices that are connected simultaneously are increased. In this case, addresses of the controllers and peripheral devices that are set in the VISCA message are locked to 0 (for the controller) or 1 (for the peripheral device).

For details of the IP address setting procedure, see “IP Related Setting Command” (page 33).

## Communication method of VISCA over IP

### Communication method

VISCA over IP can process the VISCA communication between the controllers and peripheral devices using the messages that can be identified on the LAN, and sends/receives them. Because of this, VISCA over IP is not concerned about the contents of the communication between the controllers and peripheral devices. However, the VISCA communication sequence is different, depending on the types, as follows.

### VISCA command

This is a command from the controller to the peripheral device.

When the peripheral device receives this command, Acknowledge is returned. After completing command processing, a completion notice is returned. This command uses the socket of VISCA. The order of completion notices may be changed if the multiple commands are sent to the same peripheral device.

### VISCA inquiry

This is an inquiry from the controller to the peripheral device.

When the peripheral device receives this type of command, the reply for the inquiry is returned. This command does not use the socket of VISCA. The order of the replies is not changed if a multiple commands are sent.

### VISCA reply

This is an Acknowledge, completion notice, reply, or error reply from the peripheral device to the controller. The classification for sending messages from the peripheral device to the controller is common.

### VISCA device setting command

This is the device setting command from the controller to the peripheral device.

When the peripheral device receives this classifications command, the peripheral device performs the function depend on the command.

### • Address

Sets the address of the peripheral device, and does not return a reply to the controller. While using VISCA over IP, the address command is not sent from the controller because a Network Change command from the peripheral device that triggers sending command is not issued.

### • IF\_Clear

Sends the reply message to the controller after clearing, without using VISCA socket.

### • CAM\_VersionInq

Sends the reply message to the controller, without using VISCA socket.

### Format

These are the specifications of the message header (8 bytes) and payload (1 to 16 bytes).

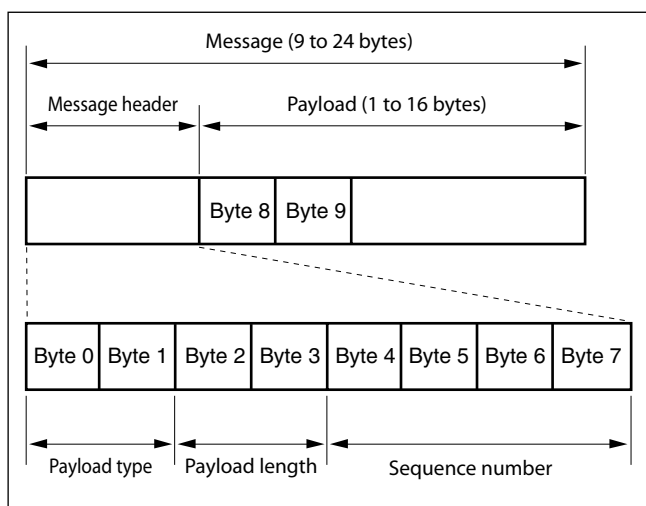

Message structure

### Note

The actual LAN out method is big-endian, LSB first.

## Payload type

Stores the value (Byte 0 and Byte 1) of the following table on the payload division.

Name	Value (Byte 0)	Value (Byte 1)	Description
VISCA command	01h	00h	Stores the VISCA command.
VISCA inquiry	01h	10h	Stores the VISCA inquiry.
VISCA reply	01h	11h	Stores the reply for the VISCA command and VISCA inquiry, or VISCA device setting command.
VISCA device setting command	01h	20h	Stores the VISCA device setting command.
Control command	02h	00h	Stores the control command.
Control reply	02h	01h	Stores the reply for the control command.

## Payload length

Stores the number of bytes (1 to 16) of data is stored on the payload.

Example: When the payload length is 16 bytes.

Byte 2: 00h

Byte 3: 10h

## Sequence number

The controller stores the sequence number that is added every time a message is sent. If the sequence number reaches the limit, next value will be 0. The peripheral device saves the sequence number in the message from the controller, and stores the sequence number of the received message corresponding to the message sent to the controller.

## Payload

Depending on the payload type, the following are stored.

### • VISCA command

Stores the packet of the VISCA command.

### • VISCA inquiry

Stores the packet of VISCA message.

### • VISCA reply

Stores the reply for the command or inquiry (Acknowledge message, completion message, or error message).

### • VISCA device setting command

Stores the packet of the VISCA device setting command.

### • Control command

The following are stored on the payload division of the control command.

Name	Value	Description
RESET	01h	Resets the sequence number to 0. The value that was set as the sequence number is ignored.
ERROR	0Fyyh	yy=01: Abnormality in the sequence number.
		yy=02: Abnormality in the message (message type)

### • Controlled reply

The following are stored on the payload division of the reply for the control command.

Message	Value	Description
Acknowledge	01h	Reply for RESET.

## Delivery confirmation

VISCA over IP uses UDP as a communications protocol of the transport layer. Delivery of messages is not guaranteed for the UDP communication. Delivery confirmation and retransmission should be performed on the application.

When the controller sends a message to the peripheral device, wait until a reply for the message is received before sending the next message. You can confirm delivery of messages by managing the time-out waiting for a reply message sent.

If time out occurs on the controller, loss of one of the following messages is considered:

- Command
- Acknowledge message
- Completion message for the command
- Inquiry
- Reply message for the inquiry
- Error message
- Inquiry of the VISCA device setting command
- Reply message of the VISCA device setting command

If time out occurs on the controller, you can infer the lost message and state of the peripheral device by retransmitting the message using the same sequence number. The following table shows the received message and status by retransmission of the lost message, and the reference of correspondence after retransmission for each case. (Except for the case that a time out occurs for reasons other than loss of message.)

Lost message	Received message for retransmission	Status after retransmission	Correspondence after retransmission
Command	Acknowledge message	Command is performed by retransmission.	Continue processing.
Acknowledge message	ERROR (Abnormality in the sequence number.)	Command has been performed. If only the Acknowledge message is lost, the completion message returns.	If the result by the completion message is needed, retransmit by updating the sequence number.
Completion message for the command	ERROR (Abnormality in the sequence number.)	Command has been performed.	If the result by the completion message is needed, retransmit by updating the sequence number.
Inquiry	Reply message	Inquiry is performed by retransmission.	Continue processing.
Reply message for the inquiry	ERROR (Abnormality in the sequence number.)	Inquiry has been performed.	If the result by the reply message is needed, retransmit by updating the sequence number.
Error message	Error message	Command is not performed. If the error cause eliminates, normal reply is returned. (Acknowledge, reply message).	Eliminate the error cause. If normal reply returns, continue processing.
Inquiry of the VISCA device setting command	Reply message of the VISCA device setting command	Inquiry has been performed by retransmission.	Continue processing.
Reply message of the VISCA device setting command	ERROR (Abnormality in the sequence number.)	Inquiry has been performed.	If the result by the reply message is needed, retransmit by updating the sequence number.

This unit has 2 sockets for the command to deal with advanced uses. When using VISCA over IP, up to 2 commands (including the current command) can be received. Depending on the message from the controller to the peripheral device, there are some messages that do not need to guarantee delivery. However, the peripheral device receives commands from multiple controllers while connected to VISCA over IP. If the multiple commands are sent without waiting for the reply, the possibility of non-execution of the command and errors due to socket overflow become high, because of limitations of order to receive commands or execution interval of command. It may reduce the substantial efficiency.



**Timing chart**

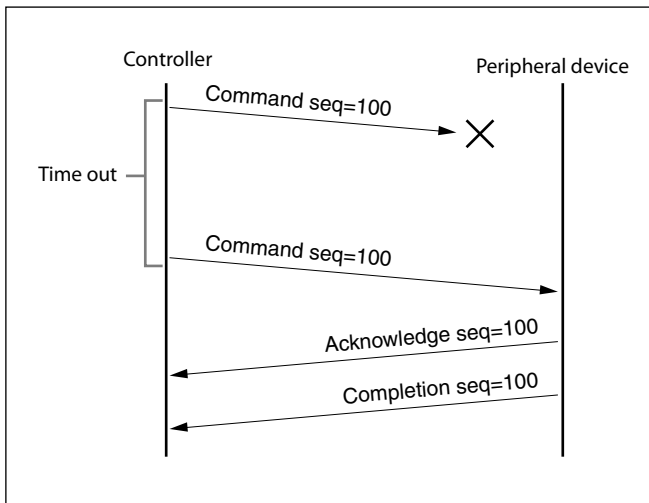

**Timing chart (loss of command)**

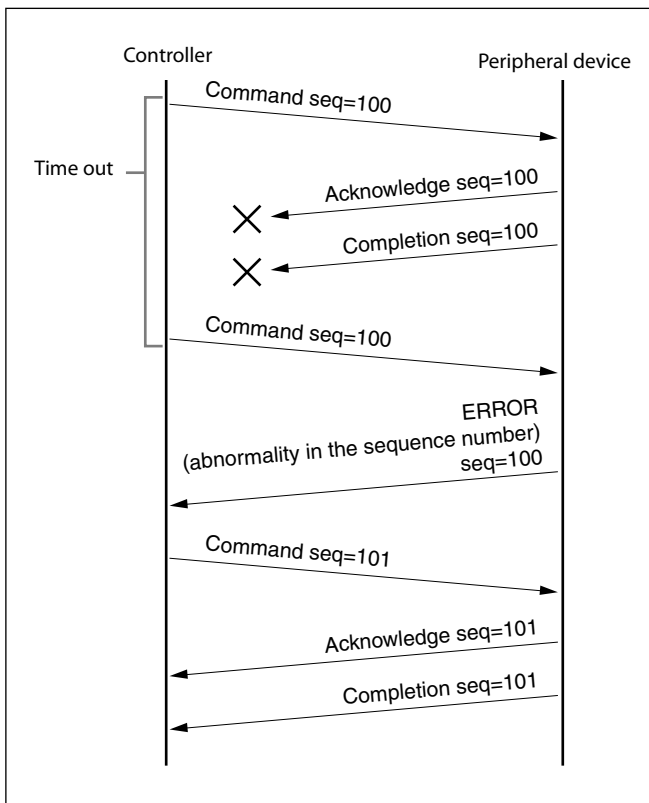

**Timing chart (loss of Acknowledge or completion message)**

# IP Related Setting Command

The following commands are provided for setting the IP address and name of this unit.

No.	Name	Description
1	Setting Protocol: Inquiry	The controller inquires the network setting for the camera.
2	Setting Protocol: Inquiry reply	The camera replies according to the inquiry from the controller.
3	Setting Protocol: Network setting	The controller sets the network setting of the camera.
4	Setting Protocol: Network setting reply	The camera replies according to the network setting of the controller.

The network setting of the IP card is performed as communication sequence in the following.

## 1 Inquiry

The controller sends the inquiry packet to the broadcast address (255.255.255.255), specified port number (52380) of UDP. The IP card replies as the inquiry reply packet.

## 2 Network setting

The controller sends the network setting packet to the broadcast address (255.255.255.255), specified port number (52380) of UDP. The receiving side sees the MAC address unit in the packet, and returns Acknowledge as the network setting reply if it is the request for the receiving side.

Command	Data
Inquiry	02 ENQ:network 1)
UDP	FF
Broadcast address (255.255.255.255)	03
Specified port number (52380)	
Inquiry reply	02 MAC:**_**_**_**_**_** 1)
UDP	FF
Broadcast address (255.255.255.255)	MODEL:IPCARD 1)
Specified port number (52380)	FF SOFTVERSION:**.**.**. 1)
	FF IPADR:**.**.**.**. 1)
	FF MASK:**.**.**.**. 1)
	FF GATEWAY:**.**.**.**. 1)
	FF NAME:xxxxxxx 1)
	FF WRITE:on 1)
	FF 03
Network setting	02 MAC:**_**_**_**_**_** 1)
UDP	FF
Broadcast address (255.255.255.255)	IPADR:**.**.**.**. 1)
Specified port number (52380)	FF MASK:**.**.**.**. 1)
	FF GATEWAY:**.**.**.**. 1) 4)
	FF 4)
	NAME:xxxxxxx 1)
	FF
	03
Network setting reply	02 ACK:**_**_**_**_**_** 2)
UDP	“xxxx” 3)
Broadcast address (255.255.255.255)	FF
Specified port number (52380)	03

- 1) Uses the ASCII code.
- 2) Uses the ASCII code. When the network setting has failed, returns as "NAK:\*\*\_\*\*\_\*\*\_\*\*\_\*\*\_\*\*".
- 3) Uses the ASCII code. Returns by adding the detail message, if necessary. There may not be it.
- 4) When GATEWAY is not used, sends as "GATEWAY:0.0.0.0 FF".

#### Note

A maximum of 8 characters including alphanumeric characters and blanks can be used for the name.

# SRG-300H Commands

## Execution Command List (1/4)

Command Set	Command	Command Packet	Comments	
AddressSet	Broadcast	88 30 01 FF	Address setting	
IF_Clear	Broadcast	88 01 00 01 FF	I/F Clear	
CommandCancel	—	8x 2p FF	p: Socket No. (=1or2)	
CAM_Power	On	8x 01 04 00 02 FF	Power ON/OFF	
	Off	8x 01 04 00 03 FF		
CAM_Zoom	Stop	8x 01 04 07 00 FF	Zoom Control	
	Tele (Standard)	8x 01 04 07 02 FF		
	Wide (Standard)	8x 01 04 07 03 FF		
	Tele (Variable)	8x 01 04 07 2p FF		p=0 (Low) to 7 (High)
	Wide (Variable)	8x 01 04 07 3p FF		
	Direct	8x 01 04 47 0p 0q 0r 0s FF		pqrs: Zoom Position
CAM_DZoom	On	8x 01 04 06 02 FF	Digital zoom ON/OFF <sup>5)</sup>	
	Off	8x 01 04 06 03 FF		
CAM_Focus	Stop	8x 01 04 08 00 FF	Focus Control	
	Far (Standard)	8x 01 04 08 02 FF		
	Near (Standard)	8x 01 04 08 03 FF		
	Far (Variable)	8x 01 04 08 2p FF		p=0 (Low) to 7 (High)
	Near (Variable)	8x 01 04 08 3p FF		
	Direct	8x 01 04 48 0p 0q 0r 0s FF		pqrs: Focus Position
	Auto Focus	8x 01 04 38 02 FF		AF ON/OFF
	Manual Focus	8x 01 04 38 03 FF		
	Auto/Manual	8x 01 04 38 10 FF		
	One Push Trigger	8x 01 04 18 01 FF		One Push AF Trigger
	Infinity	8x 01 04 18 02 FF		Forced infinity
Near Limit	8x 01 04 28 0p 0q 0r 0s FF	pqrs: Focus Near Limit Position		
AF Sensitivity	Normal	8x 01 04 58 02 FF	AF Sensitivity High/Low	
	Low	8x 01 04 58 03 FF		
CAM_AFMode	Normal AF	8x 01 04 57 00 FF	AF Movement Mode	
	Interval AF	8x 01 04 57 01 FF		
	Zoom Trigger AF	8x 01 04 57 02 FF		
	Active/Interval Time	8x 01 04 27 0p 0q 0r 0s FF		pq: Movement Time, rs: Interval
CAM_IRCorrection	Standard	8x 01 04 11 00 FF	FOCUS IR Correction setting	
	IR Light	8x 01 04 11 01 FF		
CAM_ZoomFocus	Direct	8x 01 04 47 0p 0q 0r 0s 0t 0u 0v 0w FF	pqrs: Zoom Position tuvw: Focus Position	
CAM_WB	Auto	8x 01 04 35 00 FF	Normal Auto	
	Indoor	8x 01 04 35 01 FF	Indoor mode	
	Outdoor	8x 01 04 35 02 FF	Out door mode	
	One Push WB	8x 01 04 35 03 FF	One Push WB mode	
	ATW	8x 01 04 35 04 FF	Auto Tracing White Balance	
	Manual	8x 01 04 35 05 FF	Manual Control Mode	
	One Push Trigger <sup>1)</sup>	8x 01 04 10 05 FF	One Push WB Trigger	
CAM_RGain	Reset	8x 01 04 03 00 FF	Manual Control of R Gain	
	Up	8x 01 04 03 02 FF		
	Down	8x 01 04 03 03 FF		
	Direct	8x 01 04 43 00 00 0p 0q FF		pq: R Gain
CAM_BGain	Reset	8x 01 04 04 00 FF	Manual Control of B Gain	
	Up	8x 01 04 04 02 FF		
	Down	8x 01 04 04 03 FF		
	Direct	8x 01 04 44 00 00 0p 0q FF		pq: B Gain

## Execution Command List (2/4)

Command Set	Command	Command Packet	Comments
CAM_AE	Full Auto	8x 01 04 39 00 FF	Automatic Exposure mode
	Manual	8x 01 04 39 03 FF	Manual Control mode
	Shutter Priority	8x 01 04 39 0A FF	Shutter priority Exposure mode
	Iris Priority	8x 01 04 39 0B FF	Iris priority Exposure mode
	Bright <sup>2)</sup>	8x 01 04 39 0D FF	Bright Mode(Manual control)
CAM_SlowShutter	Auto	8x 01 04 5A 02 FF	Auto Slow Shutter ON/OFF
	Manual	8x 01 04 5A 03 FF	
CAM_Shutter	Reset	8x 01 04 0A 00 FF	Shutter Setting
	Up	8x 01 04 0A 02 FF	
	Down	8x 01 04 0A 03 FF	
	Direct	8x 01 04 4A 00 00 0p 0q FF	pq: Shutter Position
CAM_Iris	Reset	8x 01 04 0B 00 FF	Iris Setting
	Up	8x 01 04 0B 02 FF	
	Down	8x 01 04 0B 03 FF	
	Direct	8x 01 04 4B 00 00 0p 0q FF	pq: Iris Position
CAM_Gain	Reset	8x 01 04 0C 00 FF	Gain Setting
	Up	8x 01 04 0C 02 FF	
	Down	8x 01 04 0C 03 FF	
	Direct	8x 01 04 4C 00 00 0p 0q FF	pq: Gain Position
	AE Gain Limit	8x 01 04 2C 0p FF	p: Gain Position (4 to F)
CAM_Bright	Up	8x 01 04 0D 02 FF	—
	Down	8x 01 04 0D 03 FF	
	Direct	8x 01 04 4D 00 00 0p 0q FF	pq: Bright Position
CAM_ExpComp	On	8x 01 04 3E 02 FF	Exposure Compensation ON/OFF
	Off	8x 01 04 3E 03 FF	
	Reset	8x 01 04 0E 00 FF	Exposure Comp Amount Setting
	Up	8x 01 04 0E 02 FF	
	Down	8x 01 04 0E 03 FF	
	Direct	8x 01 04 4E 00 00 0p 0q FF	pq: ExpComp Position
CAM_BackLight	On	8x 01 04 33 02 FF	Back Light Comp ON/OFF
	Off	8x 01 04 33 03 FF	
CAM_WD	Off	8x 01 7E 04 00 00 FF	Wide Dynamic Range Mode
	Low	8x 01 7E 04 00 01 FF	
	Mid	8x 01 7E 04 00 02 FF	
	High	8x 01 7E 04 00 03 FF	
CAM_Defog	On	8x 01 04 37 02 00 FF	Defog Mode
	Off	8x 01 04 37 03 00 FF	
CAM_Aperture	Reset	8x 01 04 02 00 FF	Aperture Setting
	Up	8x 01 04 02 02 FF	
	Down	8x 01 04 02 03 FF	
	Direct	8x 01 04 42 00 00 0p 0q FF	pq: Aperture Gain
CAM_HR	On	8x 01 04 52 02 FF	High-Resolution Mode ON/OFF
	Off	8x 01 04 52 03 FF	
CAM_NR	—	8x 01 04 53 0p FF	p: NR Setting (0:OFF, Level1 to 5)
CAM_Gamma	—	8x 01 04 5B 0p FF	p: Gamma setting 0: Standard 1: OFF
CAM_HighSensitivity	On	8x 01 04 5E 02 FF	High Sensitivity mode ON/OFF
	Off	8x 01 04 5E 03 FF	
CAM_PictureEffect	Off	8x 01 04 63 00 FF	Picture Effect Setting
	Neg.Art	8x 01 04 63 02 FF	
	B&W	8x 01 04 63 04 FF	

## Execution Command List (3/4)

Command Set	Command	Command Packet	Comments	
CAM_ICR	On	8x 01 04 01 02 FF	Infrared Mode ON/OFF	
	Off	8x 01 04 01 03 FF		
CAM_AutoICR	On	8x 01 04 51 02 FF	Auto Infrared mode ON/OFF	
	Off	8x 01 04 51 03 FF		
	Threshold	8x 01 04 21 00 00 0p 0q FF		pq: ICR ON→OFF threshold level
CAM_Stabilizer	On	8x 01 04 34 02 FF	Stabilizer ON/OFF <sup>5)</sup>	
	Off	8x 01 04 34 03 FF		
	Hold	8x 01 04 34 00 FF	Stabilizer HOLD <sup>5)</sup>	
CAM_Memory	Reset	8x 01 04 3F 00 0p FF	p: Memory number (=0 to F)	
	Set	8x 01 04 3F 01 0p FF		
	Recall	8x 01 04 3F 02 0p FF		
CAM_IDWrite	—	8x 01 04 22 0p 0q 0r 0s FF	pqrs: Camera ID (=0000 to FFFF)	
CAM_ChromaSuppress	—	8x 01 04 5F pp FF	pp: Chroma Suppress setting level 00: OFF 1 to 3: ON (3 levels). Effect increases as the level number increases.	
CAM_ColorGain	Direct	8x 01 04 49 00 00 0p 0q FF	p: Color specification q: Gain setting level The range of p is from 0 to 6. 0 : master, 1 : magenta, 2 : red, 3 : yellow, 4 : green, 5 : cyan, 6 : blue The range of q is from 0 to E. The initial value is 4. Gain Up with 5 or more, Gain Down with 3 or less.	
CAM_ColorHue	Direct	8x 01 04 4F 00 00 0p 0q FF	p: Color specification q: Phase setting level The range of p is from 0 to 6. 0 : master, 1 : magenta, 2 : red, 3 : yellow, 4 : green, 5 : cyan, 6 : blue The q is setting level of phase and the range is from 0 to E. The initial value is 7. Phase (+ direction) with 8 or more, Phase (- direction) with 6 or less.	
CAM_LowLatency <sup>6)</sup>	Low	8x 01 7E 01 5A 02 FF	Video Latency setting	
	Normal	8x 01 7E 01 5A 03 FF		
SYS_Menu	Off	8x 01 06 06 03 FF	Erasing menu display	
Video Format Change <sup>4)</sup> (Video System Rotary Switch 7: only VISCA Control enabled)	—	8x 01 7E 01 1E 0p 0q FF	pq	
			0	1920 × 1080p/59.94
			2	1920 × 1080p/29.97
			3	1920 × 1080i/59.94
			4	1280 × 720p/59.94
			5	1280 × 720p/29.97
			8	1920 × 1080p/50
			A	1920 × 1080p/25
			B	1920 × 1080i/50
			C	1280 × 720p/50
D	1280 × 720p/25			
Color System Set <sup>4)</sup>	—	8x 01 7E 01 03 00 0p FF	p	
			0	HDMI YUV
			1	HDMI GBR
			2	DVI GBR
			3	DVI YUV

## Execution Command List (4/4)

Command Set	Command	Command Packet	Comments
IR_Receive	On	8x 01 06 08 02 FF	Infrared remote commander reception ON/OFF
	Off	8x 01 06 08 03 FF	
	On/Off	8x 01 06 08 10 FF	
IR_ReceiveReturn	On	8x 01 7D 01 03 00 00 FF	For details of ON/OFF Reply of IR ReceiverReturn (a function to return Reply via VISCA communication when a command is received from the remote commander), see page 41.
	Off	8x 01 7D 01 13 00 00 FF	
Information Display	On	8x 01 7E 01 18 02 FF	Operation status screen display ON/OFF of One Push Trigger for CAM_Memor and CAM_WB
	Off	8x 01 7E 01 18 03 FF	
Pan-tiltDrive	Up <sup>3)</sup>	8x 01 06 01 VV WW 03 01 FF	VV <sup>7)</sup> : Pan speed setting 0x01 (low speed) to 0x18 (high speed) WW <sup>7)</sup> : Tilt speed setting 0x01 (low speed) to 0x17 (high speed) YYYY: Pan Position DE00 to 2200 (CENTER 0000) ZZZZ: Tilt Position FC00 to 1200 (Image Flip: OFF) (CENTER 0000) Tilt Position EE00 to 0400 (Image Flip: ON) (CENTER 0000)
	Down <sup>3)</sup>	8x 01 06 01 VV WW 03 02 FF	
	Left <sup>3)</sup>	8x 01 06 01 VV WW 01 03 FF	
	Right <sup>3)</sup>	8x 01 06 01 VV WW 02 03 FF	
	UpLeft <sup>3)</sup>	8x 01 06 01 VV WW 01 01 FF	
	UpRight <sup>3)</sup>	8x 01 06 01 VV WW 02 01 FF	
	DownLeft <sup>3)</sup>	8x 01 06 01 VV WW 01 02 FF	
	DownRight <sup>3)</sup>	8x 01 06 01 VV WW 02 02 FF	
	Stop <sup>3)</sup>	8x 01 06 01 VV WW 03 03 FF	
	AbsolutePosition	8x 01 06 02 VV WW 0Y 0Y 0Y 0Y 0Z 0Z 0Z 0Z FF	
	RelativePosition	8x 01 06 03 VV WW 0Y 0Y 0Y 0Y 0Z 0Z 0Z 0Z FF	
	Home	8x 01 06 04 FF	
	Reset	8x 01 06 05 FF	
Pan-tiltLimitSet	LimitSet	8x 01 06 07 00 0W 0Y 0Y 0Y 0Y 0Z 0Z 0Z 0Z FF	W: 1 UpRight YYYY: Pan Limit Position DE01 to 2200 ZZZZ: Tilt Limit Position FC01 to 1200 (Image Flip: OFF) Tilt Limit Position EE01 to 0400 (Image Flip: ON) W: 0 DownLeft YYYY: Pan Limit Position DE00 to 21FF ZZZZ: Tilt Limit Position FC00 to 11FF (Image Flip: OFF) Tilt Limit Position EE00 to 03FF (Image Flip: ON)
	LimitClear	8x 01 06 07 01 0W 07 0F 0F 0F 07 0F 0F 0F FF	
Pan-tiltSet SlowPanTilt	On	8x 01 06 44 02 FF	Pan/Tilt Slow Mode On/Off
	Off	8x 01 06 44 03 FF	

- 1) After the ACK for One Push WB Trigger is issued, "Not Executable" is returned to all commands until the operation is completed.
- 2) Bright is set only in the mode of Full Auto or Shutter Priority.
- 3) Does not operate when the menu is displayed.
- 4) Do not turn off the power of this unit before the response to the command is returned.  
In case that the power is turned off, the image may not be output correctly. In such case, try to execute the operation using the different setting value once, and then execute the operation using the correct setting value.
- 5) When CAM\_LowLatency is set to Low, "Not Executable" is returned.
- 6) Do not turn off the power of this unit before the response to the command is returned.  
In case that the power is turned off, the setting may not be reflected correctly. In such case, try to execute the operation using the different setting value once, and then execute the operation using the correct setting value.
- 7) When the PAN/TILT SLOW mode is set to ON, you can set up to 0x7F.  
For details, refer to "VISCA Command Setting Values".

## Inquiry Command List (1/3)

Inquiry Command	Command Packet	Inquiry Packet	Comments
CAM_PowerInq	8x 09 04 00 FF	y0 50 02 FF	On
		y0 50 03 FF	Off
CAM_ZoomPosInq	8x 09 04 47 FF	y0 50 0p 0q 0r 0s FF	pqrs: Zoom Position
CAM_DZoomModeInq	8x 09 04 06 FF	y0 50 02 FF <sup>1)</sup>	D-Zoom On
		y0 50 03 FF	D-Zoom Off
CAM_FocusModeInq	8x 09 04 38 FF	y0 50 02 FF	Auto Focus
		y0 50 03 FF	Manual Focus
CAM_FocusPosInq	8x 09 04 48 FF	y0 50 0p 0q 0r 0s FF	pqrs: Focus Position
CAM_FocusNearLimitInq	8x 09 04 28 FF	y0 50 0p 0q 0r 0s FF	pqrs: Focus Near Limit Position
CAM_AFSensitivityInq	8x 09 04 58 FF	y0 50 02 FF	AF Sensitivity Normal
		y0 50 03 FF	AF Sensitivity Low
CAM_AFModeInq	8x 09 04 57 FF	y0 50 00 FF	Normal AF
		y0 50 01 FF	Interval AF
		y0 50 02 FF	Zoom Trigger AF
CAM_AFTimeSettingInq	8x 09 04 27 FF	y0 50 0p 0q 0r 0s FF	pq: Movement Time, rs: Interval
CAM_IRCorrectionInq	8x 09 04 11 FF	y0 50 00 FF	Standard
		y0 50 01 FF	IR Light
CAM_WBModeInq	8x 09 04 35 FF	y0 50 00 FF	Auto
		y0 50 01 FF	In Door
		y0 50 02 FF	Out Door
		y0 50 03 FF	One Push WB
		y0 50 04 FF	ATW
		y0 50 05 FF	Manual
CAM_RGainInq	8x 09 04 43 FF	y0 50 00 00 0p 0q FF	pq: R Gain
CAM_BGainInq	8x 09 04 44 FF	y0 50 00 00 0p 0q FF	pq: B Gain
CAM_AEModeInq	8x 09 04 39 FF	y0 50 00 FF	Full Auto
		y0 50 03 FF	Manual
		y0 50 0A FF	Shutter Priority
		y0 50 0B FF	Iris Priority
		y0 50 0D FF	Bright
CAM_SlowShutterModeInq	8x 09 04 5A FF	y0 50 02 FF	Auto
		y0 50 03 FF	Manual
CAM_ShutterPosInq	8x 09 04 4A FF	y0 50 00 00 0p 0q FF	pq: Shutter Position
CAM_IrisPosInq	8x 09 04 4B FF	y0 50 00 00 0p 0q FF	pq: Iris Position
CAM_GainPosInq	8x 09 04 4C FF	y0 50 00 00 0p 0q FF	pq: Gain Position
CAM_GainLimitInq	8x 09 04 2C FF	y0 50 0q FF	p: Gain Limit
CAM_BrightPosInq	8x 09 04 4D FF	y0 50 00 00 0p 0q FF	pq: Bright Position
CAM_ExpCompModeInq	8x 09 04 3E FF	y0 50 02 FF	On
		y0 50 03 FF	Off
CAM_ExpCompPosInq	8x 09 04 4E FF	y0 50 00 00 0p 0q FF	pq: ExpComp Position
CAM_BackLightModeInq	8x 09 04 33 FF	y0 50 02 FF	On
		y0 50 03 FF	Off
CAM_WDModeInq	8x 09 7E 04 00 FF	y0 50 00 FF	Wide Dynamic Range Mode 00 FF : OFF 01 FF : LOW 02 FF : MID 03 FF : HIGH
		y0 50 01 FF	
		y0 50 02 FF	
		y0 50 03 FF	
CAM_DefogInq	8x 09 04 37 FF	y0 50 02 00 FF	Defog Mode On
		y0 50 03 00 FF	Defog Mode Off
CAM_ApertureInq	8x 09 04 42 FF	y0 50 00 00 0p 0q FF	pq: Aperture Gain
CAM_HRModeInq	8x 09 04 52 FF	y0 50 02 FF	On
		y0 50 03 FF	Off
CAM_NRInq	8x 09 04 53 FF	y0 50 0p FF	p: NR Level
CAM_GammaInq	8x 09 04 5B FF	y0 50 0p FF	p: Gamma

## Inquiry Command List (2/3)

Inquiry Command	Command Packet	Inquiry Packet	Comments
CAM_HighSensitivityInq	8x 09 04 5E FF	y0 50 02 FF	On
		y0 50 03 FF	Off
CAM_PictureEffectModeInq	8x 09 04 63 FF	y0 50 00 FF	Off
		y0 50 02 FF	Neg.Art
		y0 50 04 FF	B&W
CAM_ICRModeInq	8x 09 04 01 FF	y0 50 02 FF	On
		y0 50 03 FF	Off
CAM_AutoICRModeInq	8x 09 04 51 FF	y0 50 02 FF	On
		y0 50 03 FF	Off
CAM_AutoICRThresholdInq	8x 09 04 21 FF	y0 50 00 00 0p 0q FF	pq: ICR ON→OFF Threshold level
CAM_Stabilizer ModeInq	8x 09 04 34 FF	y0 50 02 FF <sup>1)</sup>	On
		y0 50 03 FF	Off
		y0 50 00 FF	Hold
CAM_IDInq	8x 09 04 22 FF	y0 50 0p 0q 0r 0s FF	pqrs: Camera ID
CAM_VersionInq	8x 09 00 02 FF	y0 50 00 01	mnpq: Model Code (0513)
		mn pq rs tu vw FF	rstu: ROM version vw: Socket Number (=02) see page 27.
CAM_Stabilizer ModeInq	8x 09 04 34 FF	y0 50 02 FF	On
		y0 50 03 FF	Off
		y0 50 00 FF	Hold
CAM_ChromaSuppressInq	8x 09 04 5F FF	y0 50 pp FF	pp: Chroma Suppress setting level
CAM_ColorGainInq	8x 09 04 49 FF	y0 50 00 00 0p FF	p: ColorGain setting 0h (60%) to Eh (200%)
CAM_ColorHueInq	8x 09 04 4F FF	y0 50 00 00 0p FF	p: ColorHue setting 0h (-14 degrees) to Eh (+14 degrees)
CAM_LowLatencyInq	8x 09 7E 01 5A FF	y0 50 02 FF	Low
		y0 50 03 FF	Normal
SYS_MenuModeInq	8x 09 06 06 FF	y0 50 02 FF	ON
		y0 50 03 FF	OFF
Information Display	8x 09 7E 01 18 FF	y0 50 02 FF	ON
		y0 50 03 FF	OFF
VIDEO SystemInq	8x 09 06 23 FF	y0 50 00 FF	1920 × 1080p/59.94
		y0 50 02 FF	1920 × 1080p/29.97
		y0 50 03 FF	1920 × 1080i/59.94
		y0 50 04 FF	1280 × 720p/59.94
		y0 50 05 FF	1280 × 720p/29.97
		y0 50 08 FF	1920 × 1080p/50
		y0 50 0A FF	1920 × 1080p/25
		y0 50 0B FF	1920 × 1080i/50
		y0 50 0C FF	1280 × 720p/50
		y0 50 0D FF	1280 × 720p/25
Color SystemInq	8x 09 7E 01 03 FF	y0 50 00 FF	HDMI YUV
		y0 50 01 FF	HDMI GBR
		y0 50 02 FF	DVI GBR
		y0 50 03 FF	DVI YUV
IR_Receive	8x 09 06 08 FF	y0 50 02 FF	ON
		y0 50 03 FF	OFF



## Inquiry Command List (3/3)

Inquiry Command	Command Packet	Inquiry Packet	Comments
IR_ReceiveReturn	—	y0 07 7D 01 04 00 FF	Power ON/OFF
		y0 07 7D 01 04 07 FF	Zoom tele/wide
		y0 07 7D 01 04 38 FF	AF On/Off
		y0 07 7D 01 04 33 FF	CAM_Backlight
		y0 07 7D 01 04 3F FF	CAM_Memory
		y0 07 7D 01 06 01 FF	Pan_tiltDrive
IR_ConditionInq	8x 09 06 34 FF	y0 50 00 FF	Infrared remote commander stable reception enabled
		y0 50 01 FF	Infrared remote commander reception unstable environment
		y0 50 02 FF	Power ON by infrared remote commander (cannot be judged)
SlowPanTiltInq	8x 09 06 44 FF	y0 50 02 FF	On
		y0 50 03 FF	Off
Pan-tiltMaxSpeedInq	8x 09 06 11 FF	y0 50 ww zz FF	ww = Pan Max Speed zz = Tilt Max Speed
Pan-tiltPosInq	8x 09 06 12 FF	y0 50 0w 0w 0w 0w 0z 0z 0z 0z FF	www = Pan Position zzzz = Tilt Position
Pan-tiltModeInq	8x 09 06 10 FF	y0 50 pq rs FF	pqrs: Pan-tilt Status

1) When CAM\_LowLatency is set to Low, “y0 50 03 FF” that indicates OFF is returned.

# Block Inquiry Command List

## Lens Control System Inquiry Commands .....Command Packet 8x 09 7E 7E 00 FF

### Inquiry Packet

Byte	Bit	Comments	Byte	Bit	Comments	Byte	Bit	Comments	
0	7	Destination Address	6	7	0	12	7	0	
	6			0	6		0		
	5			0	5		0		
	4			0	4		0		
	3	Source Address		3	Focus Near Limit (H)		3	0	
	2			2			0		
	1			1			0		
	0			0			0		
1	7	0 Completion Message (50h)	7	7	0	13	7	0	
	6	1		6	0		6	0	
	5	0		5	0		5	0	
	4	1		4	0		4	AF Mode (0:Normal, 1:Interval, 2:Zoom Trigger)	
	3	0		3	Focus Near Limit (L)		3		AF Sensitivity (1:Normal, 0:Low)
	2	0		2			2	Digital Zoom (1:On, 0:Off)	
	1	0		1			1	1	Focus Mode (1:Auto, 0:Manual)
	0	0		0			0	0	0
2	7	0	8	7	0	14	7	0	
	6	0		6	0		6	0	
	5	0		5	0		5	0	
	4	0		4	0		4	0	
	3	Zoom Position (HH)		3	Focus Position (HH)		3	Low Contrast Detection (1:Yes, 0: No)	
	2			2			Camera Memory Recall (1: Executing, 0: Stopped)		
	1			1				1	Focus Command 1: Executing 0: Stopped
	0			0			0	0	Zoom Command 1: Executing 0: Stopped
3	7	0	9	7	0	15	7	1 Terminator (FFh)	
	6	0		6	0		6	1	
	5	0		5	0		5	1	
	4	0		4	0		4	1	
	3	Zoom Position (HL)		3	Focus Position (HL)		3	1	
	2			2			1		
	1			1			1		
	0			0			0	1	
4	7	0	10	7	0	15	6	1	
	6	0		6	0		5	1	
	5	0		5	0		4	1	
	4	0		4	0		3	1	
	3	Zoom Position (LH)		3	Focus Position (LH)		3	1	
	2			2			1		
	1			1			1		
	0			0			0	1	
5	7	0	11	7	0	15	7	0	
	6	0		6	0		6	0	
	5	0		5	0		5	0	
	4	0		4	0		4	0	
	3	Zoom Position (LL)		3	Focus Position (LL)		3	0	
	2			2			0		
	1			1			0		
	0			0			0		

**Camera Control System Inquiry Commands .....Command Packet 8x 09 7E 7E 01 FF**

**Inquiry Packet**

Byte	Bit	Comments
0	7	Destination Address
	6	
	5	
	4	
	3	Source Address
	2	
	1	
	0	
1	7	0 Completion Message (50h)
	6	1
	5	0
	4	1
	3	0
	2	0
	1	0
	0	0
2	7	0
	6	0
	5	0
	4	0
	3	R Gain (H)
	2	
	1	
	0	
3	7	0
	6	0
	5	0
	4	0
	3	R Gain (L)
	2	
	1	
	0	
4	7	0
	6	0
	5	0
	4	0
	3	B Gain (H)
	2	
	1	
	0	
5	7	0
	6	0
	5	0
	4	0
	3	B Gain (L)
	2	
	1	
	0	

Byte	Bit	Comments
6	7	0
	6	0
	5	0
	4	0
	3	WB Mode
	2	
	1	
	0	
7	7	0
	6	0
	5	0
	4	0
	3	Aperture Gain
	2	
	1	
	0	
8	7	0
	6	0
	5	0
	4	Exposure Mode
	3	
	2	
	1	
	9	7
6		0
5		HighResolution (1:On, 0:Off)
4		Wide D (1: Other than Off, 0: Off)
3		0
2		Back Light (1:On, 0:Off)
1		Exposure Comp. (1:On, 0:Off)
0		Slow Shutter (1:Auto, 0:Manual)
10	7	0
	6	0
	5	0
	4	Shutter Position
	3	
	2	
	1	
	11	7
6		0
5		0
4		Iris Position
3		
2		
1		
12		7
	6	0
	5	0
	4	0
	3	Gain Position
	2	
	1	
	0	
13	7	0
	6	0
	5	0
	4	Bright Position
	3	
	2	
	1	
	14	7
6		0
5		0
4		0
3		Exposure Comp. Position
2		
1		
0		
15	7	1 Terminator (FFh)
	6	1
	5	1
	4	1
	3	1
	2	1
	1	1
	0	1

Byte	Bit	Comments
11	7	0
	6	0
	5	0
	4	Iris Position
	3	
	2	
	1	
	12	7
6		0
5		0
4		0
3		Gain Position
2		
1		
0		
13	7	0
	6	0
	5	0
	4	Bright Position
	3	
	2	
	1	
	14	7
6		0
5		0
4		0
3		Exposure Comp. Position
2		
1		
0		
15	7	1 Terminator (FFh)
	6	1
	5	1
	4	1
	3	1
	2	1
	1	1
	0	1

**Other Inquiry Commands .....Command Packet 8x 09 7E 7E 02 FF**

Inquiry Packet

Byte	Bit	Comments	Byte	Bit	Comments	Byte	Bit	Comments			
0	7	Destination Address	6	7	0	12	7	0			
	6			0	6		0	6	0		
	5			0	5		0	5	0		
	4			0	4		1	4	1		
	3	Source Address		3	0		3	0	3	0	
	2			0	2		1	2	1		
	1			0	1		1	1	1		
	0			0	0		0	0	System (1:1/50, 1/25, 0:1/59.94, 1/29.97)		
1	7	0 Completion Message (50h)	7	7	0		13	7	0		
	6	1		6	0			6	0		
	5	0		5	0			5	0		
	4	1		4	0			4	0		
	3	0		3	0			3	0		
	2	0		2	0			2	0		
	1	0		1	0	1		0			
	0	0		0	0	0		0			
2	7	0	8	7	0	14		7	0		
	6	0		6	0			6	0		
	5	0		5	0			5	0		
	4	0		4	0			4	0		
	3	0		3	Camera ID (HH)			3	0	3	0
	2	Auto ICR (1:On, 0:Off)		2				0	2	0	
	1	0		1			0	1	0		
	0	Power (1:On, 0:Off)		0			0	0	0		
3	7	0	9	7	0		15	7	1 Terminator (FFh)		
	6	Stabilizer (1:On, 0:Off)		6	0			6	1		
	5	Stabilizer Hold (1:Hold, 0:Off)		5	0			5	1		
	4	ICR (1:On, 0:Off)		4	0			4	1		
	3	0		3	Camera ID (HL)			3	1		
	2	0		2				1	2	1	
	1	0		1		1		1	1		
	0	0		0		0		0	1		
4	7	0	10	7	0	11		7	0		
	6	0		6	0			6	0		
	5	0		5	0			5	0		
	4	Reserved		4	0			4	0		
	3	0		3	Camera ID (LH)			3	0		
	2	0		2				0	2	0	
	1	0		1			0	1	0		
	0	0		0			0	0	0		
5	7	0	11	7	0		11	7	0		
	6	0		6	0			6	0		
	5	0		5	0			5	0		
	4	0		4	0			4	0		
	3	Picture Effect Mode		3	Camera ID (LL)			3	0		
	2			0				2	0		
	1			0		1		0			
	0			0		0		0			

**Enlargement Function1 Query Command .....Command Packet 8x 09 7E 7E 03 FF**

Inquiry Packet

Byte	Bit	Comments	Byte	Bit	Comments	Byte	Bit	Comments			
0	7	Destination Address	6	7	0	12	7	0			
	6			0	6		0				
	5			0	5		0				
	4			0	4		0				
	3	Source Address		3	AF Interval Time (H)		3	0			
	2			2			0				
	1			1			0				
	0			0			1				
1	7	0 Completion Message (50h)	7	7		0	13	7	0		
	6	1		6		0		6	Gamma		
	5	0		5		0		5		0	
	4	1		4		0		4		0	
	3	0		3	AF Interval Time (L)	3		High Sensitivity mode (1: ON, 0: OFF)			
	2	0		2		0			2	NR Level	
	1	0		1		0			1		0
	0	0		0		0			0		0
2	7	0	8	7	0	14	7	0			
	6	0		6	0		6	Chroma Suppress			
	5	0		5	0		5		0		
	4	0		4	0		4		0		
	3	Digital Zoom Position (H)		3	1		3	Gain Limit			
	2			0	2		0				
	1			0	1		0				
	0			0	0		0				
3	7	0	9	7	0	15	7	1 Terminator (FFh)			
	6	0		6	0		6	1			
	5	0		5	0		5	1			
	4	0		4	0		4	1			
	3	Digital Zoom Position (L)		3	1		3	1			
	2			0	2		0				
	1			0	1		0				
	0			0	0		0				
4	7	0	10	7	0	11	7	0			
	6	0		6	0		6	Color Gain (Master)			
	5	0		5	0		5		0		
	4	0		4	0		4		0		
	3	AF Activation Time (H)		3	0		3		0		
	2			0	2		0				
	1			0	1		0				
	0			0	0		0				
5	7	0	11	7	0	11	7	0			
	6	0		6	Color Gain (Master)						
	5	0		5			0				
	4	0		4			0				
	3	AF Activation Time (L)		3			1	3	1		
	2			1	2		1				
	1			1	1		1				
	0			1	0		1				

**Enlargement Function2 Query Command .....Command Packet 8x 09 7E 7E 04 FF**

Inquiry Packet

Byte	Bit	Comments	Byte	Bit	Comments	Byte	Bit	Comments
0	7	Destination Address	6	7	0	12	7	0
	6			0	6		0	
	5			0	5		0	
	4			0	4		0	
	3	Source Address		3	0		3	0
	2			0	2		0	
	1			Reserved	1		0	
	0			Reserved	0		0	
1	7	0 Completion Message (50h)	7	7	0	13	7	0
	6	1		6	0		6	0
	5	0		5	0		5	0
	4	1		4	0		4	0
	3	0		3	0		3	0
	2	0		2	0		2	0
	1	0		1	0		1	0
	0	0		0	defog mode 0:Off 1:On		0	0
2	7	0	8	7	0	14	7	0
	6	0		6	0		6	0
	5	0		5	0		5	0
	4	0		4	0		4	0
	3	0		3	0		3	0
	2	0		2	0		2	0
	1	Reserved		1	0		1	0
	0	Reserved		0	0		0	0
3	7	0	9	7	0	15	7	1 Terminator (FFh)
	6	0		6	0		6	1
	5	0		5	0		5	1
	4	0		4	0		4	1
	3	0		3	0		3	1
	2	0		2	0		2	1
	1	0		1	0		1	1
	0	0		0	0		0	1
4	7	0	10	7	0	11	7	0
	6	0		6	0		6	0
	5	0		5	0		5	0
	4	0		4	0		4	0
	3	0		3	0		3	0
	2	Reserved		2	0		2	0
	1	Reserved		1	0		1	0
	0	Reserved		0	0		0	0
5	7	0	11	7	0	11	7	0
	6	0		6	0		6	0
	5	0		5	0		5	0
	4	0		4	0		4	0
	3	0		3	0		3	0
	2	0		2	0		2	0
	1	Reserved		1	0		1	0
	0	Reserved		0	0		0	0

**Enlargement Function3 Query Command .....Command Packet 8x 09 7E 7E 05 FF**

Inquiry Packet

Byte	Bit	Comments	Byte	Bit	Comments	Byte	Bit	Comments				
0	7	Destination Address	6	7	0	12	7	0				
	6			Source Address	Reserved		Reserved					
	5							0	Reserved			
	4									0	Reserved	
	3	0										Reserved
	2			0	Reserved							
	1						0	Reserved				
	0								0	Reserved		
7	0 Completion Message (50h)	7	7			0					13	7
6	1		Reserved	Reserved								
5	0				Reserved							
4	1					Reserved						
3	0						Reserved					
2	0		Reserved									
1	0			Reserved								
0	0				Reserved							
2	7	0				8	7	0	14	7	0	
	6	0	Reserved				Reserved					
	5	0		Reserved								
	4	0			Reserved							
	3	Color Hue (Master)						Reserved				
2	Reserved											
1			Reserved									
0				Reserved								
3		7			0	9	7	0	15	7	1 Terminator (FFh)	
	6	Reserved			Reserved		Reserved					
	5		Reserved					Reserved				
	4			Reserved						Reserved		
	3										Reserved	Reserved
	2	Reserved			Reserved							
	1		Reserved				Reserved					
	0			Reserved				Reserved				
4	7					0			10	7	0	15
	6	Reserved			Reserved	Reserved						
	5		Reserved				Reserved					
	4			Reserved				Reserved				
	3									Reserved	Reserved	
2	Reserved	Reserved										
1			Reserved		Reserved							
0				Reserved		Reserved						
5							7	0	11	7	0	15
	6	Reserved					Reserved	Reserved				
	5		Reserved		Reserved							
	4			Reserved		Reserved						
	3									Reserved	Reserved	
	2	Reserved					Reserved					
	1		Reserved		Reserved							
	0			Reserved		Reserved						

# VISCA Command Setting Values

## Exposure control (1/2)

		59.94/29.97 mode	50/25 mode
Shutter Speed	15	1/10000	1/10000
	14	1/6000	1/6000
	13	1/4000	1/3500
	12	1/3000	1/2500
	11	1/2000	1/1750
	10	1/1500	1/1250
	0F	1/1000	1/1000
	0E	1/725	1/600
	0D	1/500	1/425
	0C	1/350	1/300
	0B	1/250	1/215
	0A	1/180	1/150
	09	1/125	1/120
	08	1/100	1/100
	07	1/90	1/75
	06	1/60	1/50
	05	1/30	1/25
	04	1/15	1/12
	03	1/8	1/6
	02	1/4	1/3
01	1/2	1/2	
00	1/1	1/1	

Iris	11	F1.6
	10	F2
	0F	F2.4
	0E	F2.8
	0D	F3.4
	0C	F4
	0B	F4.8
	0A	F5.6
	09	F6.8
	08	F8
	07	F9.6
	06	F11
	05	F14
	00	CLOSE

Gain	0F	+43dB
	0E	+39dB
	0D	+36dB
	0C	+33dB
	0B	+30dB
	0A	+27dB
	09	+24dB
	08	+21dB
	07	+18dB
	06	+15dB
	05	+12dB
	04	+9dB
	03	+6dB
	02	+3dB
	01	0dB

Gain Limit	0F	+43dB
	0E	+39dB
	0D	+36dB
	0C	+33dB
	0B	+30dB
	0A	+27dB
	09	+24dB
	08	+21dB
	07	+18dB
	06	+15dB
	04	+9dB



**Exposure control (2/2)**

		<b>IRIS</b>	<b>GAIN</b>
Bright	1F	F1.6	+43dB
	1E	F1.6	+39dB
	1D	F1.6	+36dB
	1C	F1.6	+33dB
	1B	F1.6	+30dB
	1A	F1.6	+27dB
	19	F1.6	+24dB
	18	F1.6	+21dB
	17	F1.6	+18dB
	16	F1.6	+15dB
	15	F1.6	+12dB
	14	F1.6	+9dB
	13	F1.6	+6dB
	12	F1.6	+3dB
	11	F1.6	0dB
	10	F2	0dB
	0F	F2.4	0dB
	0E	F2.8	0dB
	0D	F3.4	0dB
	0C	F4	0dB
	0B	F4.8	0dB
	0A	F5.6	0dB
	09	F6.8	0dB
	08	F8	0dB
	07	F9.6	0dB
	06	F11	0dB
	05	F14	0dB
00	CLOSE	0	

		<b>Display</b>	<b>Compensation Amount</b>
Exposure Comp.	0E	+7	+10.5dB
	0D	+6	+9dB
	0C	+5	+7.5dB
	0B	+4	+6dB
	0A	+3	+4.5dB
	09	+2	+3dB
	08	+1	+1.5dB
	07	0	0dB
	06	-1	-1.5dB
	05	-2	-3dB
	04	-3	-4.5dB
	03	-4	-6dB
	02	-5	-7.5dB
	01	-6	-9dB
	00	-7	-10.5dB

**Optical Zoom Ratio and Zoom Position (for reference)**

Zoom Position: 0000 (Wide end) to 4000 (Tele end)

<b>Optical Zoom Ratio</b>	<b>Optical Zoom Position Data</b>
×1	0000
×2	16A1
×3	2063
×4	2628
×5	2A1D
×6	2D13
×7	2F6D
×8	3161
×9	330D
×10	3486
×11	35D7
×12	3709
×13	3820
×14	3920
×15	3A0A
×16	3ADD
×17	3B9C
×18	3C46
×19	3CDC
×20	3D60
×21	3DD4
×22	3E39
×23	3E90
×24	3EDC
×25	3F1E
×26	3F57
×27	3F8A
×28	3FB6
×29	3FDC
×30	4000

**Digital Zoom**

<b>Digital Zoom Ratio</b>	<b>Digital Zoom Position Data</b>
×1	4000
×2	6000
×3	6A80
×4	7000
×5	7300
×6	7540
×7	76C0
×8	7800
×9	78C0
×10	7980
×11	7A00
×12	7AC0

## Focus NEAR limit and focus distance

Focus position: 1000 (Far end) to F000 (Near end)

NEAR Limit	Focus Distance
1000	Over Inf
2000	20m
3000	10m
4000	6m
5000	4.2m
6000	3.1m
7000	2.5m
8000	2m
9000	1.65m
A000	1.4m
B000	1.2m
C000	80cm
D000	30cm
E000	11cm
F000	1cm

## Lens control

Zoom Position	0000 Wide end	to	4000 Optical Tele end	to	7AC0 Digital Tele end
Focus Position	1000 to F000 Far end Near end				
Focus Near Limit	1000: Over Inf 2000: 20 m 3000: 10 m 4000: 6 m 5000: 4.2 m 6000: 3.1 m 7000: 2.5 m 8000: 2.0 m 9000: 1.65 m A000: 1.4 m B000: 1.2 m C000: 0.8 m D000: 30 cm (initial setting) E000: 11 cm F000: 1 cm	As the distance on the left will differ due to temperature characteristics, etc., use as approximate values. *The lower 1 byte is fixed at 00.			

## Others

AF Active Time <sup>1)</sup>	00	to	FF
AF Interval Time <sup>1)</sup>	00	to	FF
R Gain	00	to	FF
B Gain	00	to	FF
Aperture Level	00	to	0F
AE Response	01	to	30
AutoICR ON →	00	to	1C
OFF Threshold Level			
Chroma Suppress setting level	00	to	03
Color Gain setting level	00	to	0E
Color Hue setting level	00	to	0E

<sup>1)</sup> Unit: One second

## Pan/Tilt Speed (Pan/Tilt Slow Mode= Off)

Parameter	Speed (deg/sec)	
	Pan	Tilt
01h	1.1	1.1
02h	1.3	1.3
03h	1.6	1.6
04h	2.2	2.2
05h	2.9	2.9
06h	6.7	6.7
07h	11	11
08h	23	16
09h	24	26
0Ah	27	29
0Bh	41	31
0Ch	43	34
0Dh	47	50
0Eh	49	52
0Fh	54	54
10h	57	57
11h	62	62
12h	64	64
13h	69	69
14h	72	72
15h	80	80
16h	84	84
17h	91	91
18h <sup>1)</sup>	101	—

<sup>1)</sup> The maximum speed setting value of Pan is 18h and that of Tilt is 17h. Although you can set the value up to 7Fh, the speed is kept at the maximum speed.

**Pan/Tilt Speed (Pan/Tilt Slow Mode= On)**

Parameter	Speed (deg/sec) Pan/Tilt
01h	0.50
02h	0.70
03h	0.90
04h	1.10
05h	1.30
06h	1.50
07h	1.90
08h	2.30
09h	2.70
0Ah	3.10
0Bh	3.50
0Ch	4.10
0Dh	4.70
0Eh	5.30
0Fh	5.90
10h	6.50
11h	7.30
12h	8.10
13h	8.90
14h	9.50
15h	10.80
16h	13.20
17h	26.50
18h	60.00
19h	0.10
1Ah	0.20
1Bh	0.30
1Ch	0.40
1Dh	0.50
1Eh	0.60
1Fh	0.70
20h	0.80
21h	0.90
22h	1.00
23h	1.10
24h	1.20
25h	1.30
26h	1.40
27h	1.50
28h	1.60
29h	1.70
2Ah	1.80
2Bh	1.90
2Ch	2.00
2Dh	2.10
2Eh	2.20
2Fh	2.30

Parameter	Speed (deg/sec) Pan/Tilt
30h	2.40
31h	2.50
32h	2.60
33h	2.70
34h	2.80
35h	2.89
36h	3.00
37h	3.10
38h	3.20
39h	3.30
3Ah	3.40
3Bh	3.49
3Ch	3.61
3Dh	3.71
3Eh	3.79
3Fh	3.90
40h	4.00
41h	4.10
42h	4.20
43h	4.31
44h	4.40
45h	4.49
46h	4.61
47h	4.71
48h	4.82
49h	4.89
4Ah	5.00
4Bh	5.12
4Ch	5.20
4Dh	5.32
4Eh	5.41
4Fh	5.50
50h	5.59
51h	5.69
52h	5.79
53h	5.89
54h	6.00
55h	6.11
56h	6.22
57h	6.28
58h	6.41
59h	6.47
5Ah	6.60
5Bh	6.67
5Ch	6.80
5Dh	6.87
5Eh	7.02

Parameter	Speed (deg/sec) Pan/Tilt
5Fh	7.10
60h	7.25
61h	7.33
62h	7.41
63h	7.50
64h	7.58
65h	7.76
66h	7.86
67h	7.95
68h	8.05
69h	8.15
6Ah	8.25
6Bh	8.35
6Ch	8.46
6Dh	8.57
6Eh	8.68
6Fh	8.80
70h	8.92
71h	9.04
72h	9.16
73h	9.29
74h	9.43
75h	9.56
76h	9.70
77h	9.85
78h	10.00
79h	10.15
7Ah	10.31
7Bh	10.47
7Ch	10.64
7Dh	10.82
7Eh	11.00
7Fh	11.18

## Pan/Tilt Status Code List

P	Q	R	S	
----	----	0---	---1	A Pan movement all the way to the left
----	----	0---	--1-	A Pan movement all the way to the right
----	----	0---	-1--	A Tilt movement all the way up
----	----	0---	1---	A Tilt movement all the way down
----	----	--00	----	Pan movement is correct
----	----	--01	----	Abnormal pan position detected
----	--00	0---	----	The Tilt movement is correct
----	--01	0---	----	Abnormal tilt position detected
----	00--	0---	----	No move request received
----	01--	0---	----	In the midst of a Pan/Tilt
----	10--	0---	----	Pan/Tilt completed
----	11--	0---	----	Pan/Tilt failed
--00	----	0---	----	Not initialized
--01	----	0---	----	Initializing
--10	----	0---	----	Initialization completed
--11	----	0---	----	Initialization failed

(- : optional)

## Pan/Tilt Position (for reference)

	Parameter (position)
PAN	DE00 (-170 degree) to 2200 (+170 degree)
TILT	FC00 (-20 degree) to 1200 (+90 degree) (Image Flip: OFF) EE00 (-90 degree) to 0400 (+20 degree) (Image Flip: ON)

## LED Status

	Status	POWER (Green)	STANDBY (Orange)
<b>Main power ON</b>	<b>Power On</b> (including initializing period)	On	Off
	When receiving infrared signals from Infrared Remote Commander	Blinking	Off
	At position detection error	On	Blinking
	<b>Standby status</b> Power off by VISCA or the Infrared Remote Commander	Off	On
<b>Main power Off</b>		Off	Off
<b>Initialization error</b>	Pan/tilt error	Blinking	Blinking
<b>BOTTOM switch and SYSTEM SELECT switch</b>	Setting error (Example: when the SYSTEM SELECT switch is set to position "1, 9, E or F")	On	On

# Specifications

## System

Video signal	1920 × 1080p/59.94 1920 × 1080p/29.97 1920 × 1080i/59.94 1280 × 720p/59.94 1280 × 720p/29.97 1920 × 1080p/50 1920 × 1080p/25 1920 × 1080i/50 1280 × 720p/50 1280 × 720p/25 EDID VISCA CONTROL (switched with the SYSTEM SELECT switch)
Synchronization	Internal synchronization
Image device	1/2.8 type Exmor CMOS
Lens	30× (optical), 12× (digital) f = 4.3 mm (wide) to 129 mm (tele) F1.6 to 4.7 Horizontal angle: 65 degrees (WIDE end)
Minimum object distance	10 mm (13/32 inch) (WIDE end) to 1200 mm (47 1/4 inch) (TELE end)
Minimum illumination	1.4 lux (F1.6, 50 IRE, high-sensitivity mode OFF, 30fps) 2.8 lux (F1.6, 50 IRE, high-sensitivity mode OFF, 60fps) 0.35 lux (F1.6, 50 IRE, high- sensitivity mode ON, 30fps) 0.7 lux (F1.6, 50 IRE, high-sensitivity mode ON, 60fps)
Shutter speed	1/1 to 1/10000 sec. (22 steps)
Video S/N	50 dB

Pan/tilt action	Horizontal: ±170 degrees Maximum panning speed: 100 degrees/sec. Vertical: +90, -20 degrees (IMAGE FLIP: OFF) +20, -90 degrees (IMAGE FLIP: ON) Maximum tilting speed: 90 degrees/sec.
-----------------	--

## Input/output connectors

HDMI video	Type A (19-pin)
Control input/output	VISCA IN: Mini DIN 8-pin type, RS-232 VISCA OUT: Mini DIN 8-pin type, RS-232 VISCA RS-422: 9-pin LAN connector: RJ-45 (8-pin), 10BASE-T/100BASE-TX auto discrimination
Power connector	JEITA type4 (DC 12 V)

## General

Input voltage	DC 12 V (DC 10.8 to 13.2 V)
Power consumption	16.8 W
Operating temperature	0 °C to 40 °C (32 °F to 104 °F)
Storage temperature	-20 °C to +60 °C (-4 °F to 140 °F)
Dimensions	Video camera: 157 × 164 × 163 mm (6 1/4 × 6 1/2 × 6 1/2 inches) (w/h/d) Infrared Remote Commander: 56 × 26 × 210 mm (2 1/4 × 1 1/16 × 8 3/8 inches) (w/h/d)
Installation angle	Less than ±15 degrees to the horizontal surface

**Supplied accessories**

AC power adaptor (1)  
AC power cord (1)  
Infrared Remote Commander (1)  
Ceiling bracket (A) (1)  
Ceiling bracket (B) (1)  
Wire rope (1)  
Screw M3×8 (8)  
VISCA RS-422 connector plug (1)  
For safety (1)  
Operating Instructions (CD-ROM) (1)

Design and specifications are subject to change without notice.

The terms HDMI and HDMI High-Definition Multimedia Interface, and the HDMI Logo are trademarks or registered trademarks of HDMI Licensing LLC in the United States and other countries.

The HDMI logo is displayed in a bold, black, sans-serif font. The letters are thick and closely spaced, with a distinctive design where the 'H' and 'M' have a slightly irregular, blocky appearance.

**Dimensions**

**Top**

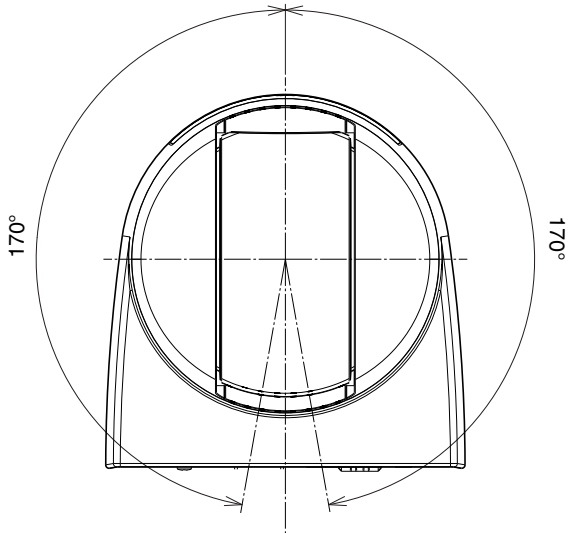

**Rear**

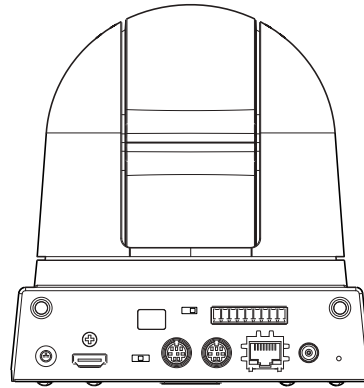

**Front**

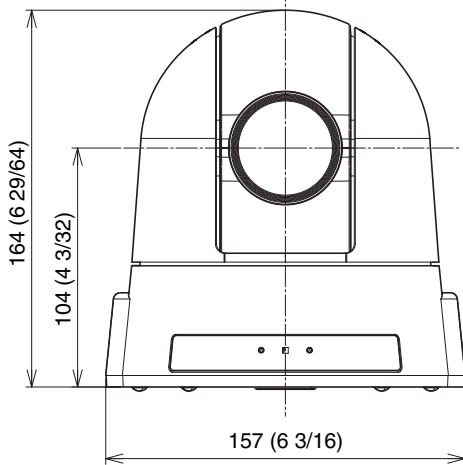

**Side**

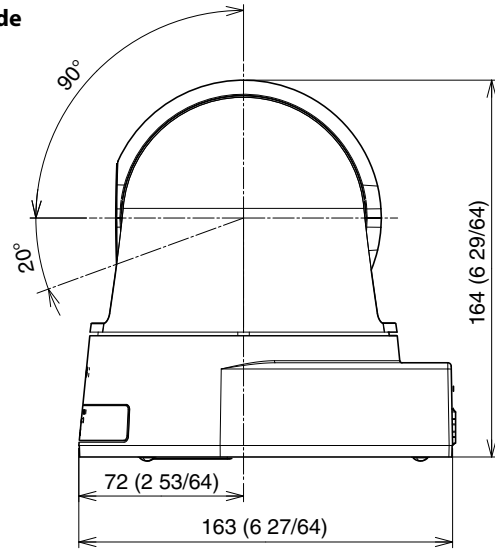

**Bottom**

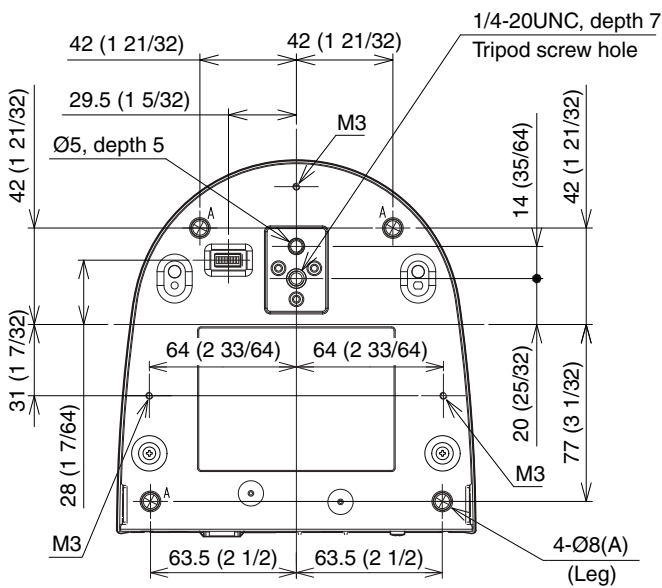

Unit: mm (inch)

**Dimensions with ceiling bracket**

**Front**

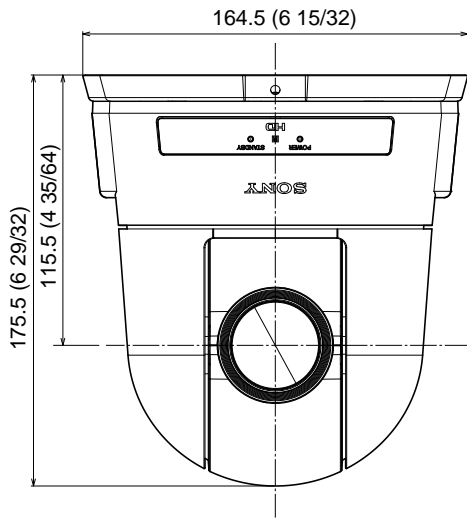

**Side**

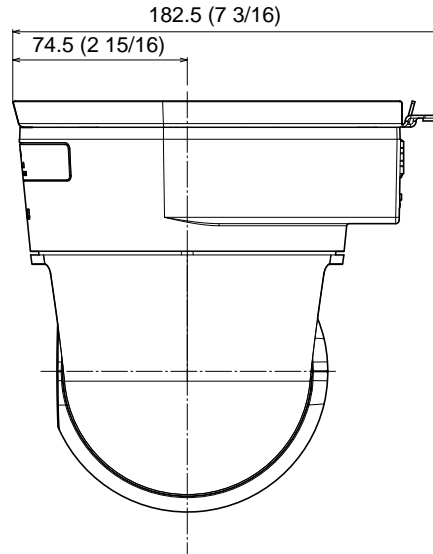

**Ceiling bracket (B)**

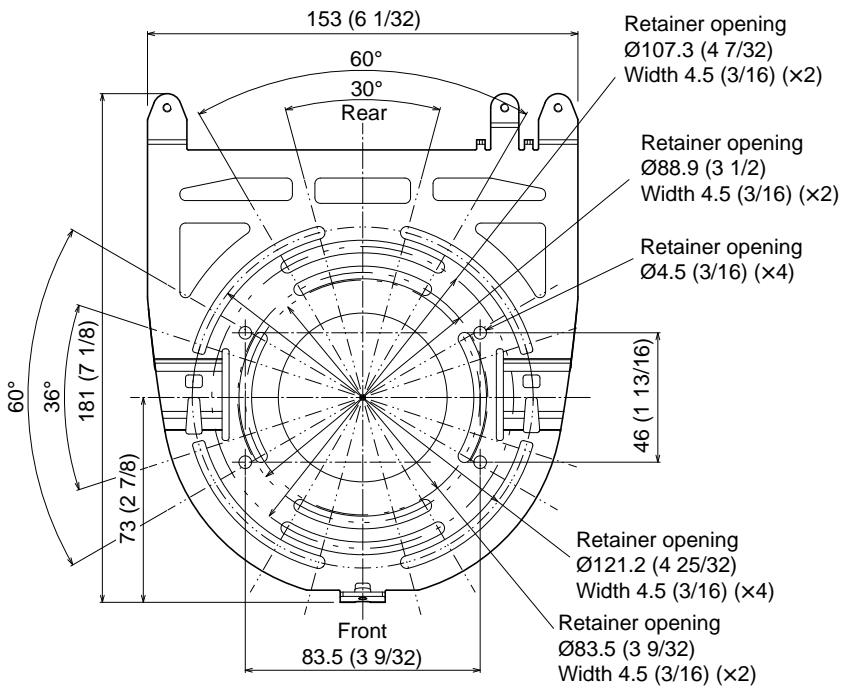

Unit: mm (inch)



## Pin assignments

### VISCA IN connector (mini-DIN 8-pin, female)

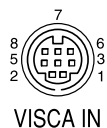

Pin No.	Function
1	DTR IN
2	DSR IN
3	TXD IN
4	GND
5	RXD IN
6	GND
7	IR OUT R*
8	IR OUT L*

\* The IR OUT function of pins 7 and 8 are selectable with the BOTTOM switch on the bottom of the camera.

### VISCA OUT connector (mini DIN 8-pin, female)



Pin No.	Function
1	DTR OUT
2	DSR OUT
3	TXD OUT
4	GND
5	RXD OUT
6	GND
7	No connection
8	No connection

## Using the VISCA RS-422 connector pin assignments

### The VISCA RS-422 connector pin assignments

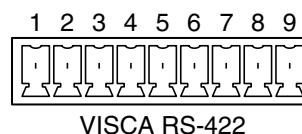

Pin No.	Function
1	TXD IN+
2	TXD IN-
3	RXD IN+
4	RXD IN-
5	GND
6	TXD OUT+
7	TXD OUT-
8	RXD OUT+
9	RXD OUT-

### Using the VISCA RS-422 connector plug

- 1 Insert a wire (AWG Nos. 28 to 18) into the desired wire opening on the supplied VISCA RS-422 connector plug, and tighten the screw for that wire using a flat-head screwdriver.

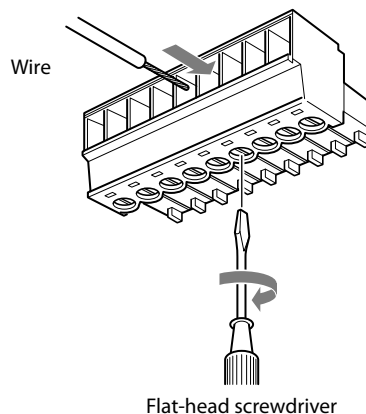

- 2 Insert the VISCA RS-422 connector plug into the VISCA RS-422 connector on the rear of the camera.

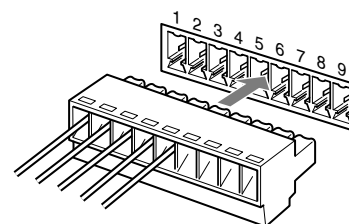

#### Notes

- In order to stabilize the voltage level of the signal, connect both ends to GND.
- Do not make a VISCA RS-232 connection when there is already an existing VISCA RS-422 connection.

## License

This software partially supports component uIP.  
Therefore the following license conditions apply.

Copyright (c) 2001-2006, Adam Dunkels and the  
Swedish Institute of Computer Science All rights  
reserved.

Redistribution and use in source and binary forms,  
with or without modification, are permitted provided  
that the following conditions are met:

1. Redistributions of source code must retain the above  
copyright notice, this list of conditions and the  
following disclaimer.
2. Redistributions in binary form must reproduce the  
above copyright notice, this list of conditions and the  
following disclaimer in the documentation and/or  
other materials provided with the distribution.
3. The name of the author may not be used to endorse  
or promote products derived from this software  
without specific prior written permission.

THIS SOFTWARE IS PROVIDED BY THE AUTHOR  
'AS IS' AND ANY EXPRESS OR IMPLIED  
WARRANTIES, INCLUDING, BUT NOT LIMITED  
TO, THE IMPLIED WARRANTIES OF  
MERCHANTABILITY AND FITNESS FOR A  
PARTICULAR PURPOSE ARE DISCLAIMED. IN NO  
EVENT SHALL THE AUTHOR BE LIABLE FOR ANY  
DIRECT, INDIRECT, INCIDENTAL, SPECIAL,  
EXEMPLARY, OR CONSEQUENTIAL DAMAGES  
(INCLUDING, BUT NOT LIMITED TO,  
PROCUREMENT OF SUBSTITUTE GOODS OR  
SERVICES; LOSS OF USE, DATA, OR PROFITS; OR  
BUSINESS INTERRUPTION) HOWEVER CAUSED  
AND ON ANY THEORY OF LIABILITY, WHETHER  
IN CONTRACT, STRICT LIABILITY, OR TORT  
(INCLUDING NEGLIGENCE OR OTHERWISE)  
ARISING IN ANY WAY OUT OF THE USE OF THIS  
SOFTWARE, EVEN IF ADVISED OF THE  
POSSIBILITY OF SUCH DAMAGE.

# Precautions

---

## Software

Use of the demonstration software developed by Sony Corporation or use of the software with customer developed application software may damage hardware, the application program or the camera. Sony Corporation is not liable for any damages under these conditions.

---

## Operation

Start the demonstration software on your computer after you turn on the camera and the image is displayed.

---

## Operation and storage locations

Do not shoot images that are extremely bright (e.g., light sources, the sun, etc.) for long periods of time. Do not use or store the camera in the following extreme conditions:

- Extremely hot or cold places (operating temperature 0 °C to 40 °C (32 °F to 104 °F))
- Close to generators of powerful electromagnetic radiation such as radio or TV transmitters
- Where it is subject to fluorescent light reflections
- Where it is subject to unstable (flickering, etc.) lighting conditions
- Where it is subject to strong vibration

---

## Care of the unit

Remove dust or dirt on the surface of the lens with a blower (commercially available).

---

## Other

Do not apply excessive voltage. (Use only the specified voltage.) Otherwise, you may get an electric shock or a fire may occur.

In case of abnormal operation, contact your authorized Sony dealer or the store where you purchased the product.