

6 5 4 3 2 1

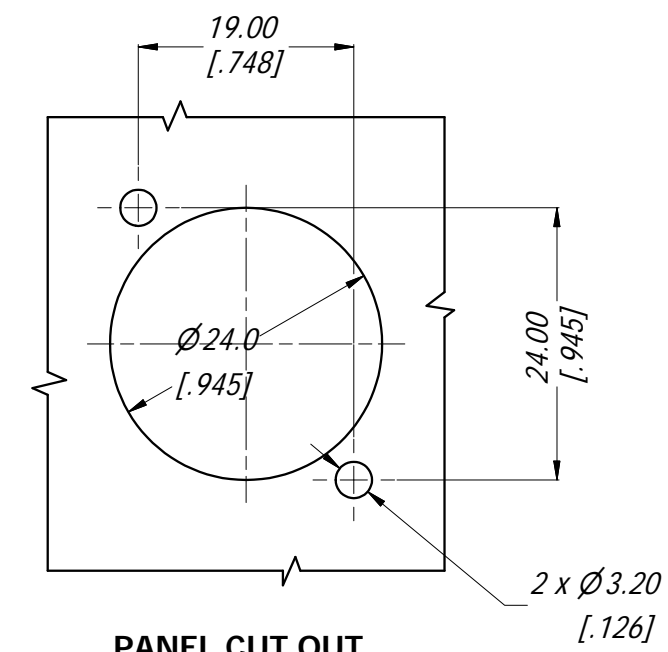

PANEL CUT OUT
3:2
(CONNECTOR FRONT VIEW)

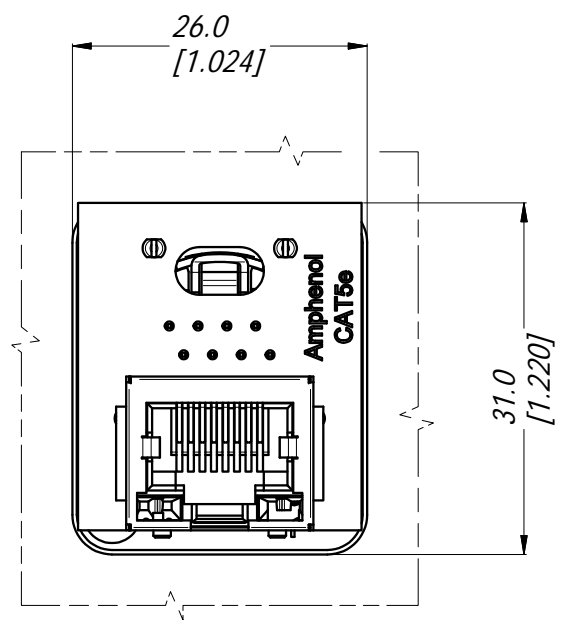
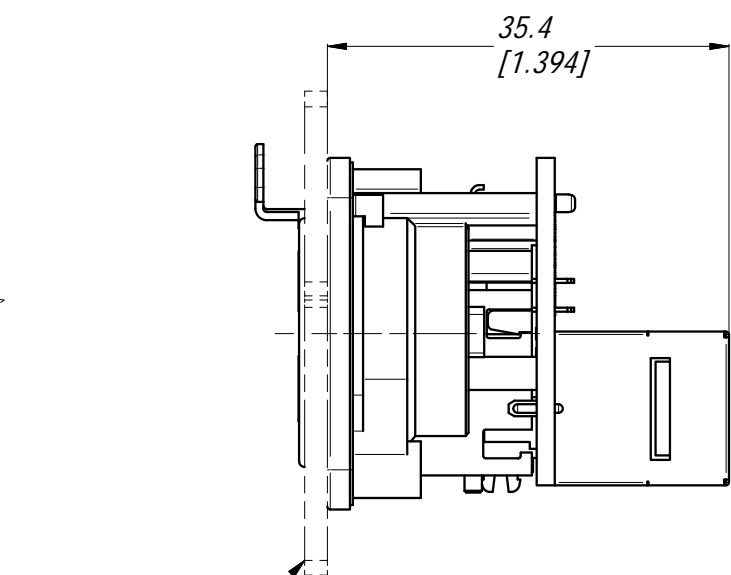
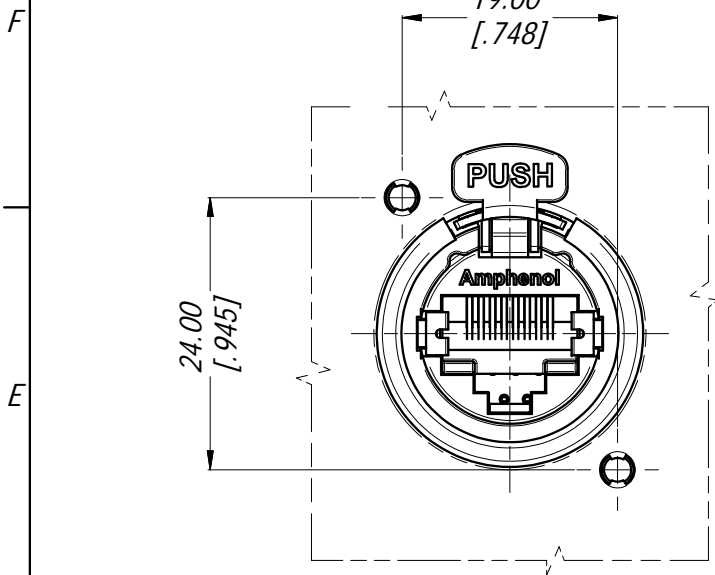
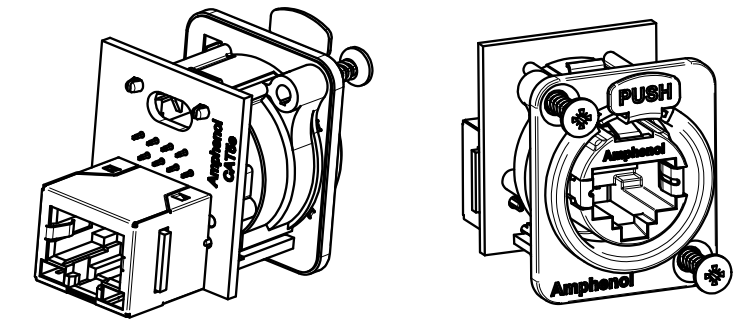
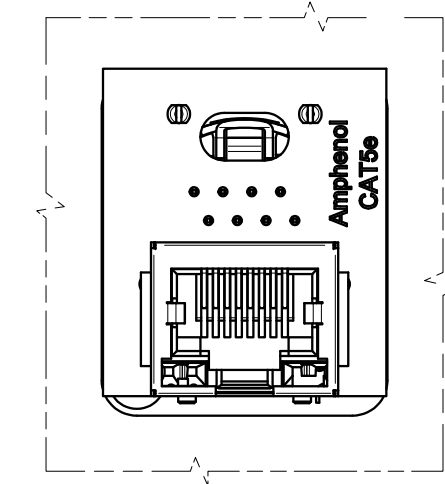
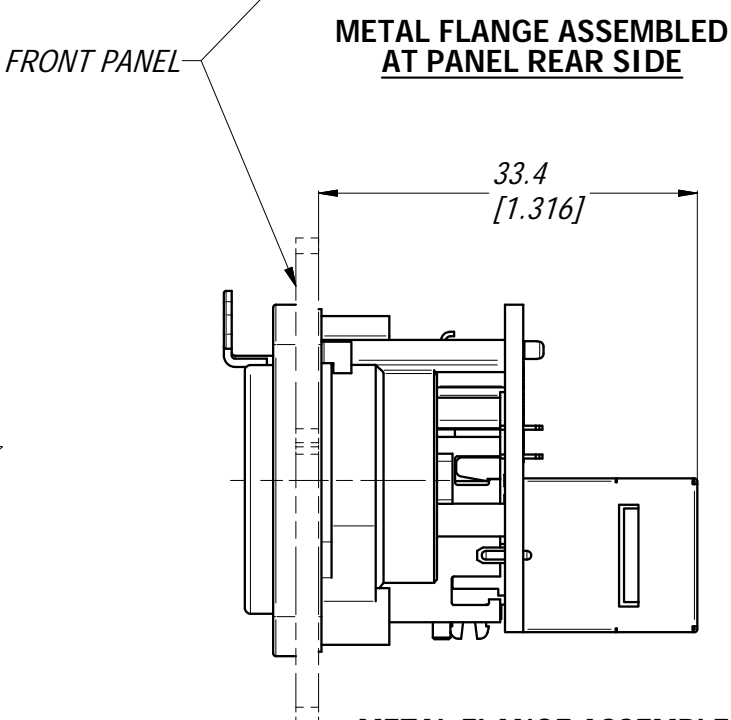
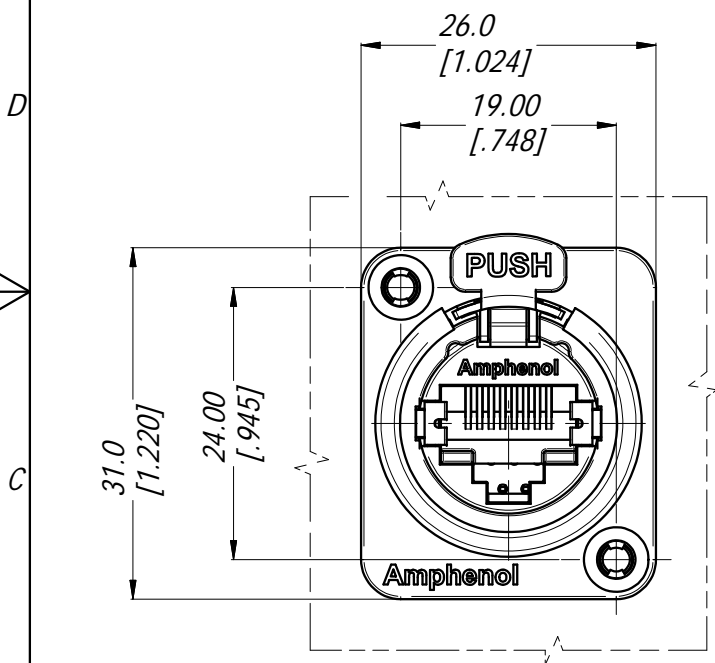

3D VIEW
1:1

- SPECIFICATIONS:**
- MATERIALS:**
 - PLASTIC INSERT & HOUSING: HIGH TEMPERATURE THERMOPLASTIC FLAMMABILITY RATING UL94V-0 DSM Stanyl, 30% BLACK
 - FRONT METAL SHELL: ZINC ALLOY ZAMAK 3, NICKEL PLATE (B TYPE).
 - CONTACTS: PHOSPHORE BRONZE, 1.27 um GOLD PLATE ON MATING SURFACES, 1.27 um NICKEL MIN UNDERPLATE. 3.81 um MIN MATTE TIN ON CONTACT TAILS.
 - LATCH LOCK AND SPRING: SPRING STEEL, NICKEL PLATE.
 - EMI/RFI HOOD: BRASS, TIN PLATE
 - ELECTRICAL CHARACTERISTICS:**
 - RATED VOLTAGE: 125 VAC
 - TYPICAL CONTACT RESISTANCE: 20 mOhm
 - INSULATION RESISTANCE: >500 MOhm
 - DIELECTRIC STRENGTH: 1000 VAC, 60 SECONDS
 - TRANSMISSION SPECIFICATION/CLASS: COMPLIES WITH CAT5e 1000 BASE-T PER EIA-568-C.2 AND ISO 11801
 - PoE+ COMPLIES WITH 802.3at Type 2



UNLESS OTHERWISE SPECIFIED TOLERANCE TO BE		THIS DOCUMENT IS THE PROPERTY OF AMPHENOL AUSTRALIA PTY. LTD. NO PART THEREOF MAY BE REPRODUCED AND USED WITHOUT THE PRIOR WRITTEN CONSENT OF THE OWNER.				Amphenol		Amphenol Australia Pty.Ltd, 20 Industry Blvd, Carrum Downs VIC 3201 Australia	
LINER	ANGULAR	MATERIAL:	DRN:	T.N	DATE:	06/03/14	TITLE:	PART No:	REV
X ± 0.5	X' ± 1	REFER SPECIFICATION	CKD:	P.M	DATE:	06/03/14	XLRnet D TYPE CAT5e	RJX8FD5TB	1
X.X ± 0.1	X.X' ± 30'								
X.X ± 0.05	X.X' ± 15'	FINISH:	APP'D:	P.M	DATE:	06/03/14	FEEDTHROUGH ADAPTOR	DRAWING No.	SHEET
DO NOT SCALE		THIRD ANGLE PROJECTION		SCALE:	3:2	SIZE:	A3	55010961-000	1/1
DIMENSIONS IN MILLIMETRES									

6 5 4 3 2 1