

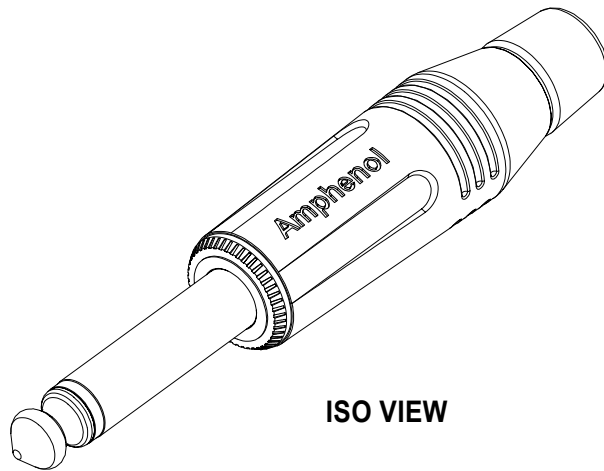

PEAK
CONFERENCE
www.PeakConference.com

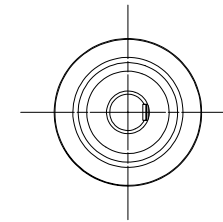

ISO VIEW

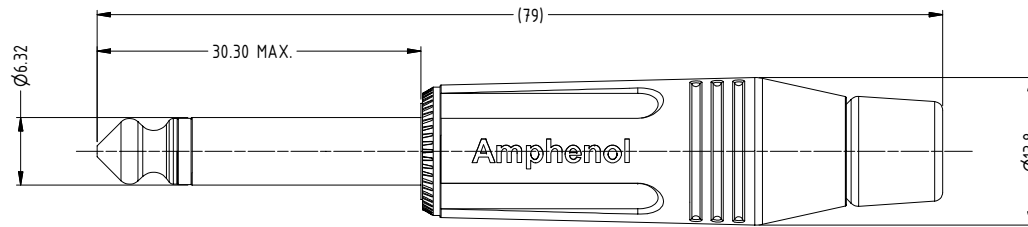
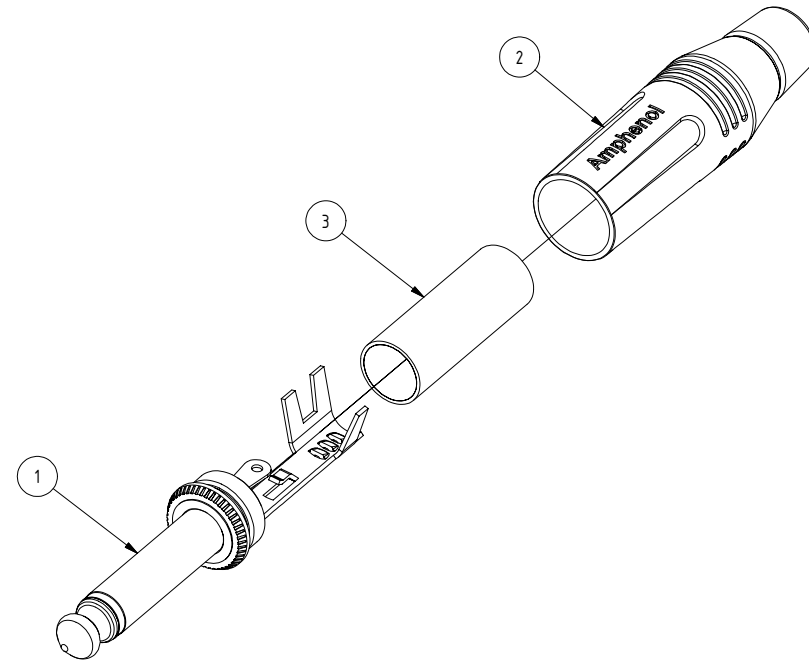

Parts List				
ITEM	PART NUMBER	DWG No	DESCRIPTION	QTY
1	50310007-*30	50310007-130-1	INSERT ASSEMBLY	1
2	53490001-*31	53490001-331-1	BACKSHELL ASSEMBLY	1
3	51270016-521	51270013-521-1	PVC INSULATION TUBE	1

Part Numbers According to Shell and Contact Finish			
CATALOGUE P/No	REFERENCE P/No.	SHELL FINISH	CONTACT FINISH
ACPM-GN	55010218-000	NICKEL	NICKEL SLEEVE AND TIP
ACPM-GN-AU	55010218-001	NICKEL	GOLD SLEEVE AND TIP
ACPM-GB	55010218-002	BLACK	NICKEL SLEEVE AND TIP
ACPM-GB-AU	55010218-003	BLACK	GOLD SLEEVE AND TIP

UNLESS OTHERWISE SPECIFIED TOLERANCE TO BE	LINEAR	ANGULAR	THIS DOCUMENT IS THE PROPERTY OF AMPHENOL AUSTRALIA PTY LTD. NO PART THEREOF MAY BE REPRODUCED AND USED WITHOUT THE PRIOR WRITTEN CONSENT OF THE OWNER		1	UPDATE TO MODIFIED COMPONENTS	LV	1/03/2004	8241
	X ± 0.5 XX ± 0.1 XXX ± 0.05	X' ± 1 X'X' ± 30' X'X'X' ± 15'	CAD FILE: 55010218000111	DSD: T.N	DATE: 7/12/2002	0	FIRST ISSUE	T.N	7/12/2002
BREAK ALL SHARP EDGES AND REMOVE ALL BURRS	MATL: REFER TO COMPONENTS	CKD: M.N.H	DATE: 04-05-04	DATE: 04-05-04	CHANGE DETAILS		BY	DATE	CHG/No
DO NOT SCALE	FINISH: SEE TABLE	APP'D: P.M	DATE: 04-05-04	TITLE: 1/4" PHONE PLUG MONO ASSY		DRAWING NO.		SHEET	
DIMENSIONS IN MILIMETRES	THIRD ANGLE PROJECTION	SCALE: 2:1 UOS	PART No: SEE TABLE	SIZE: A3	55010218-000-1		1/1		

Amphenol

Amphenol Australia Pty Ltd, 2 Fineways Blvd, Keysborough, Vic3173