

MIN MOUNTING PITCH
ACTUAL SIZE

CONTACTS SCHEMATIC CHART

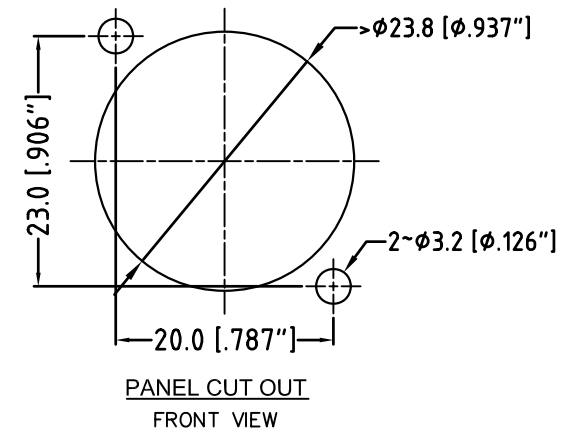
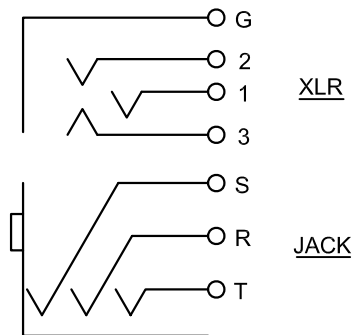

| | | | | | | | | | | |
|--|--------------|---|--------------------|----------|----------|-------------|--|--------------------------------|----------|------|
| UNLESS OTHERWISE SPECIFIED TOLERANCE TO BE | | THIS DOCUMENT IS THE PROPERTY OF AMPHENOL AUSTRALIA PTY. LTD. NO PART THEREOF MAY BE REPRODUCED AND USED WITHOUT THE PRIOR WRITTEN CONSENT OF THE OWNER | | | | 1 | Correct Minimum Mounting Pitch dimension from 14mm to 27mm | M.H | 19-03-09 | 8811 |
| LINEAR | ANGULAR | CAD FILE: 55010428000111 | | | | REV. | FIRST ISSUE | M.H | 05-10-07 | ---- |
| X ± 0.5 | X° ± 1° | | | | | DATE: | 05-10-07 | CHG/No | --- | |
| X.X ± 0.1 | X°X' ± 30' | | | | | DRN: | M.H | BY | --- | |
| X.XX ± 0.05 | X°X'X" ± 15" | DATE: | 19-03-09 | DATE: | 19-03-09 | TITLE: | | ACJC6S C-TYPE CUSTOMER DRAWING | | |
| BREAK ALL SHARP EDGES AND REMOVE ALL BURRS | | MATL: | REFER TO COMPONENT | APP'D: | P.M | DRAWING NO. | | 55010428-000-1 | | |
| DO NOT SCALE | | FINISH: | REFER TO COMPONENT | SCALE: | 2:1 UDS | SHEET | | 2 OF 2 | | |
| DIMENSIONS IN MILLIMETRES | | THIRD ANGLE PROJECTION | | PART No: | | ACJC6S | | SIZE: A3 | | |

Amphenol
Amphenol Australia Pty.Ltd, 2 Fireways Blvd, Keysborough, Vic3173